

STRUCTURAL DESIGN-I

CHAPTER-1

INTRODUCTION TO DESIGN AND DETAILING

Objectives Of Design and Detailing

Every structure must be **designed** to satisfy three basic requirements;

- 1) **Stability** to prevent overturning, sliding or buckling of the structure, or parts of it, under the action of loads;
- 2) **Strengths** to resist safely the stresses induced by the loads in the various structural members;
- 3) **Serviceability** to ensure satisfactory performance under service load conditions – which implies providing adequate stiffness to contain deflections , crackwidths and vibrations within acceptable limits , and also providing impermeability , durability etc.

There are two other considerations that a sensible designer ought to bear in mind, viz. **economy** and **aesthetics**.

A good structural design often involving elaborate computations is a worthwhile exercise if only it is followed by good detailing and construction practices. In normal design practices it is often seen that analysis of structures for stress resultants and design of individual members (critical sections of beams, slabs and columns) for maximum load effects(bending moments, shear, torsion and axial forces) are done regularly with insufficient attention given to supposedly lesser important aspects e.g. termination, extending and bending of bars, anchorage and development, stirrup anchorage, splices, construction details at joints or connections (slab-beam, beam-column etc.), provision of continuity and discontinuity at connection of members , construction sequencing and reinforcement placement, deflection calculations and control, crack control, cover to reinforcement ,creep and shrinkage etc.

The factors as enumerated above are very critical from the point of view of a successful structure and needs to be fairly assessed with sufficient accuracy and spelt out in detail through various drawings and specifications by the designer so that the construction of the structure can be handled by the site engineer.

Advantages Of Reinforced Concrete

The following are major advantages of reinforced cement concrete (RCC)

- Reinforced Cement Concrete has good compressive stress (because of concrete).
- RCC also has high tensile stress (because of steel).
- It has good resistance to damage by fire and weathering (because of concrete).
- RCC protects steel bars from buckling and twisting at the high temperature.

- RCC prevents steel from rusting.
- Reinforced Concrete is durable.
- The monolithic character of reinforced concrete gives it more rigidity.
- Maintenance cost of RCC is practically nil.

It is possible to produce steel whose yield strength is 3 to 4 time more that of ordinary reinforced steel and to produce concrete 4 to 5 time stronger in compression than the ordinary concrete. This may high strength material offer many advantages including smaller member cross-sections, reduce dead load and longer spans.

Different Methods of Design

Over the years, various design philosophies have evolved in different parts of the world, with regard to reinforced concrete design. A design philosophy is built upon a few fundamental assumptions and is reflective of a way of thinking.

Working Stress Method:

The earliest codified design philosophy is that of **working stress method** of design (WSM). Close to a hundred years old, this traditional method of design, based on linear elastic theory is still surviving in a number of countries. In WSM it is assumed that structural material e.g. concrete and steel behave in linearly elastic manner and adequate safety can be ensured by restricting the stresses in the material induced by working loads (service loads) on the structure. As the specified permissible (allowable) stresses are kept well below the material strength, the assumption of linear elastic behavior considered justifiable. The ratio of the strength of the material to the permissible stress is often referred to as the factor of safety. While applying WSM the stresses under applied loads are analysed by ‘simple bending theory’ where strain compatibility is assumed(due to bond between concrete and steel).

Ultimate Load Method:

With the growing realization of the shortcomings of WSM in reinforced concrete design, and with increased understanding of the behavior of reinforced concrete at *ultimate loads*, the ultimate load method of design (ULM) evolved in the 1950s and became an alternative to WSM. This method is sometimes also referred to as the *load factor method* or the *ultimate strength method*.

In this method, the stress condition at the state of impending collapse of the structure is analysed, and the nonlinear stress-strain curve of concrete and steel are made use of the concept of ‘modular ratio’ and its associated problems are avoided. The safety measure in the design is introduced by an appropriate choice of the load factor, defined as the ratio of the ultimate load(design load) to the working load. This method

generally results in more slender sections, and often more economical design of beams and columns (compared to WSM), particularly when high strength reinforcing steel and concrete are used.

Limit State Method:

The philosophy of the limit state method of design (LSM) represents a definite advancement over the traditional WSM (based on service load conditions alone) and ULM (based on ultimate load conditions alone). LSM aims for a comprehensive and rational solution to the design problem, by considering safety at ultimate loads and serviceability at working loads. The LSM uses a multiple safetyfactor format which attempts to provide adequate safety at ultimate loads as well as adequate serviceability at service loads by considering all possible 'limit states'.

CHAPTER-2

WORKING STRESS METHOD OF DESIGN

General Concept

Working stress method is based on the behavior of a section under the load expected to be encountered by it during its service period. The strength of concrete in the tension zone of the member is neglected although the concrete does have some strength for direct tension and flexural tension (tension due to bending). The material both concrete and steel, are assumed to behave perfectly elastically, i.e., stress is proportional to strain. The distribution of strain across a section is assumed to be linear. The section that are plane before bending remain plane after bending. Thus, the strain, hence stress at any point is proportional to the distance of the point from the neutral axis. With this a triangular stress distribution in concrete is obtained, ranging from zero at neutral axis to a maximum at the compressive face of the section. It is further assumed in this method that there is perfect bond between the steel and the surrounding concrete, the strains in both materials at that point are same and hence the ratio of stresses in steel and concrete will be the same as the ratio of elastic moduli of steel and concrete. This ratio being known as 'modular ratio', the method is also called 'Modular Ratio Method'.

In this method, external forces and moments are assumed to be resisted by the internal compressive forces developed in concrete and tensile resistive forces in steel and the internal resistive couple due to the above two forces, in concrete acting through the centroid of triangular distribution of the compressive stresses and in steel acting at the centroid of tensile reinforcement. The distance between the lines of action of resultant resistive forces is known as 'Lever arm'.

Moments and forces acting on the structure are computed from the service loads. The section of the component member is proportioned to resist these moments and forces such that the maximum stresses developed in materials are restricted to a fraction of their true strengths. The factors of safety used in getting maximum permissible stresses are as follows:

<i>Material</i>	<i>Factor of Safety</i>
For concrete 3.0	For Steel
	1.78

Assumptions of WSM

The analysis and design of a RCC member are based on the following assumptions.

- (i) Concrete is assumed to be homogeneous.
- (ii) At any cross section, plane sections before bending remain plane after bending.
- (iii) The stress-strain relationship for concrete is a straight line, under working loads.
- (iv) The stress-strain relationship for steel is a straight line, under working loads.
- (v) Concrete area on tension side is assumed to be ineffective.
- (vi) All tensile stresses are taken up by reinforcements and none by concrete except when specially permitted.
- (vii) The steel area is assumed to be concentrated at the centroid of the steel.
- (viii) The modular ratio has the value $280/3\sigma_{cbc}$ where σ_{cbc} is permissible stress in compression due to bending in concrete in N/mm^2 as specified in code (IS:456-2000)

Moment of Resistance

- (a) *For Balanced section:* When the maximum stresses in steel and concrete simultaneously reach their allowable values, the section is said to be a 'Balanced Section'. The moment of resistance shall be provided by the couple developed by compressive force acting at the centroid of stress diagram on the area of concrete in compression and tensile force acting at the centroid of reinforcement multiplied by the distance between these forces. This distance is known as 'lever arm'.

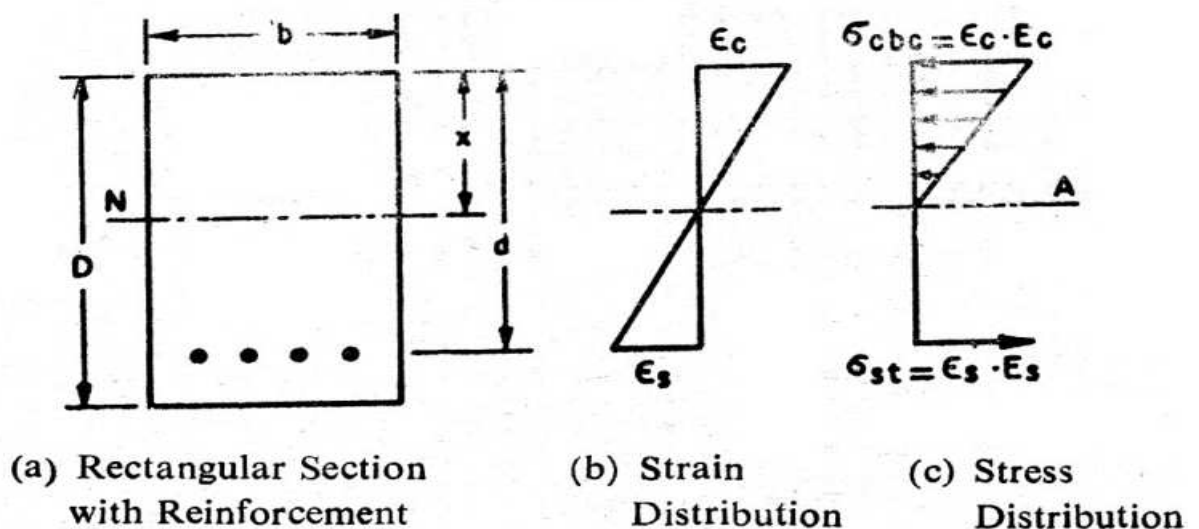

Fig.2.1 (a-c)

Let in Fig.2.1(a-c): b = width of section

D = overall depth of section

d = effective depth of section (distance from extreme compression fiber to the centroid of steel area,

A_s = area of tensile steel

ϵ_c = Maximum strain in concrete,

ϵ_s = maximum strain at the centroid of the steel,

σ_{cbc} = maximum compressive stress in concrete in bending

σ_{st} = Stress in steel

E_s/E_c = ratio of Young's modulus of elasticity of steel to concrete
= modular ratio ' m '

Since the strains in concrete and steel are proportional to their distances from the neutral axis,

$$\frac{\epsilon_c}{\epsilon_s} = \frac{x}{d-x} \quad \text{or} \quad \frac{d-x}{x} = \frac{\epsilon_s}{\epsilon_c}$$

$$\frac{d}{x} - 1 = \frac{\sigma_{st}}{E_s} \frac{E_c}{\sigma_{cbc}} = \frac{\sigma_{st}}{\sigma_{cbc}} \frac{1}{m}$$

Or
$$\frac{d}{x} = 1 + \frac{\sigma_{st}}{m \cdot \sigma_{cbc}} \quad \text{or} \quad x = \frac{1}{1 + \frac{\sigma_{st}}{m \cdot \sigma_{cbc}}} \cdot d = k \cdot d$$

Where k = neutral axis constant =
$$\frac{1}{1 + \frac{\sigma_{st}}{m \cdot \sigma_{cbc}}}$$

Total compressive force =
$$\frac{b \cdot x \cdot \sigma_{cbc}}{2}$$

Total tensile forces =
$$\sigma_{st} \cdot A_s$$

$$Z = \text{Lever arm} = d - \frac{x}{3} = d - \frac{k \cdot d}{3} = d \left(1 - \frac{k}{3} \right) = j \cdot d$$

Where j is called the lever arm constant.

Moment of resistance =
$$MR = \frac{b \cdot x}{2} \cdot \sigma_{cbc} \cdot j \cdot d = \frac{k \cdot d \cdot j}{2} \cdot \sigma_{cbc} \cdot b \cdot d = \frac{1}{2} \cdot k \cdot j \cdot \sigma_{cbc} \cdot b \cdot d^2 = Q \cdot b \cdot d^2$$

Where Q is called moment of resistance constant and is equal to
$$\frac{1}{2} \cdot k \cdot j \cdot \sigma_{cbc}$$

(b) Under reinforced section

When the percentage of steel in a section is less than that required for a balanced section, the section is called 'Under-reinforced section.' In this case (Fig.2.2) concrete stress does not reach its maximum allowable value while the stress in steel reaches its maximum permissible value. The position of the neutral axis will shift upwards, i.e., the neutral axis depth will be smaller than that in the balanced section as shown in Figure2.2. The moment of resistance of such a section will be governed by allowable tensile stress in steel.

$$\text{Moment of resistance} = \sigma_{st} \cdot A_s \cdot \left(d - \frac{x}{3} \right) = \sigma_{st} A_s \cdot j' d \quad \text{where } j' = 1 - \frac{k'}{3}$$

$$\text{Since } p = \frac{A_s \cdot 100}{b \cdot d}$$

$$\text{Moment of resistance} = \sigma_{st} \cdot p \cdot \frac{b \cdot d}{100} \cdot j' \times d = \frac{\sigma_{st} \cdot p \cdot j'}{100} \cdot b \cdot d^2 = Q' \cdot Bb \cdot d^2 \quad \text{where } Q' = \frac{\sigma_{st} \cdot p \cdot j'}{100}$$

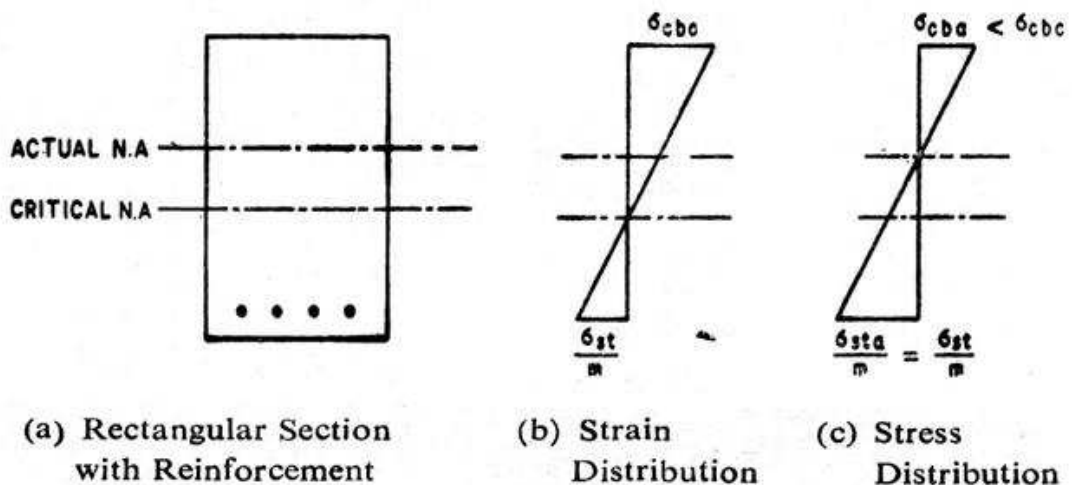

Fig.2.2 (a-c)

(c) Over reinforced section:

When the percentage of steel in a section is more than that required for a balanced section, the section is called 'Over-reinforced section'. In this case (Fig.2.3) the stress in concrete reaches its maximum allowable value earlier than that in steel. As the percentage steel is more, the position of the neutral axis will shift towards steel from the critical or balanced neutral axis position. Thus the neutral axis depth will be greater than that in case of balanced section.

Moment of resistance of such a section will be governed by compressive stress in concrete,

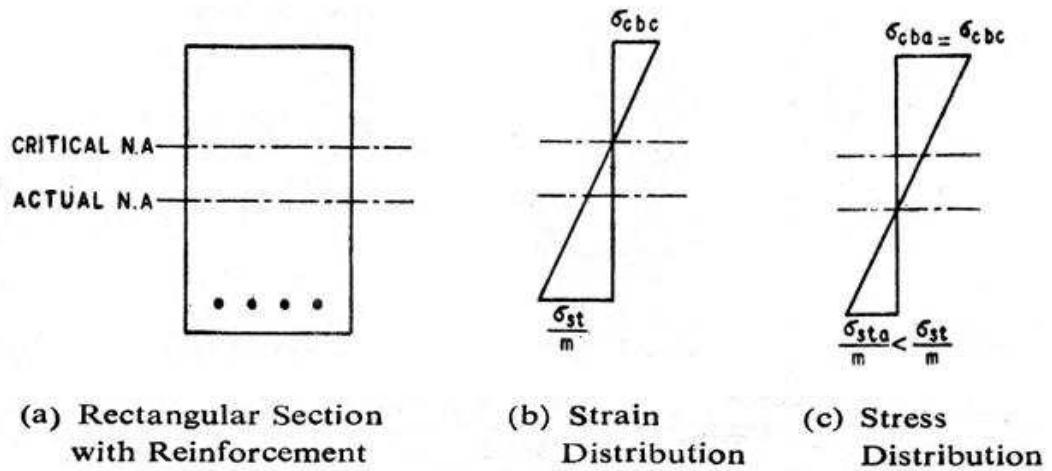

Fig.2.3 (a-c)

$$\begin{aligned} \text{Moment of resistance} &= b \cdot x \cdot \sigma_{cbc} \cdot \frac{1}{2} \left(d - \frac{x}{3} \right) = \frac{\sigma_{cbc}}{2} \cdot b \cdot x \cdot d \cdot \left(1 - \frac{k'}{3} \right) \\ &= \frac{\sigma_{cbc}}{2} \cdot b \cdot x \cdot d \cdot j' = \frac{1}{2} \cdot \sigma_{cbc} \cdot k' \cdot j' \cdot b \cdot d^2 = Q' \cdot b \cdot d^2 \quad \text{where } Q' = \frac{\sigma_{cbc}}{2} \cdot k' \cdot j' = \text{Constant} \end{aligned}$$

Basic concept of design of single reinforced members

The following types of problems can be encountered in the design of reinforced concrete members.

(A) Determination of Area of Tensile Reinforcement

The section, bending moment to be resisted and the maximum stresses in steel and concrete are given.

Steps to be followed:

- (i) Determine k, j, Q (or Q') for the given stress.
 - (ii) Find the critical moment of resistance, $M = Q \cdot b \cdot d^2$ from the dimensions of the beam.
 - (iii) Compare the bending moment to be resisted with M , the critical moment of resistance.
- (a) If B.M. is less than M , design the section as under reinforced.

$$M = \sigma_{st} \cdot A_s \cdot \left(d - \frac{x}{3} \right)$$

To find A_s in terms of x , take moments of areas about $N.A.$

$$b \cdot x \cdot \frac{x}{2} = m \cdot A_s \cdot (d - x)$$

$$A_s = \frac{b \cdot x^2}{2(m)(d - x)} \therefore M = \frac{\sigma_{st} \cdot b \cdot x^2}{2 \cdot m \cdot (d - x)} \left(d - \frac{x}{3} \right) = B.M. \text{ to be resisted}$$

Solve for 'x', and then A_s can be calculated.

- (b) If $B.M.$ is more than M , design the section as over-reinforced.

$$M = \frac{\sigma_{cbc}}{2} \cdot b \cdot x \cdot \left(d - \frac{x}{3} \right) = B.M. \text{ to be resisted. Determine 'x'. Then } A_s \text{ can be obtained by taking}$$

moments of areas (compressive and tensile) about using the following expression.

$$A_s = \frac{b \cdot x^2}{2 \cdot m \cdot (d - x)}$$

(B) Design of Section for a Given loading

Design the section as balanced section for the given loading.

Steps to be followed:

- (i) Find the maximum bending moment ($B.M.$) due to given loading.
- (ii) Compute the constants k, j, Q for the balanced section for known stresses.
- (iii) Fix the depth to breadth ratio of the beam section as 2 to 4.
- (iv) From $M = Q \cdot b \cdot d^2$, find 'd' and then 'b' from depth to breadth ratio.
- (v) Obtain overall depth 'D' by adding concrete cover to 'd' the effective depth.
- (vi) Calculate A_s from the relation

$$A_s = \frac{B.M.}{\sigma_{st} \cdot j \cdot d}$$

(C) To Determine the Load carrying Capacity of a given Beam

The dimensions of the beam section, the material stresses and area of reinforcing steel are given.

Steps to be followed:

- (i) Find the position of the neutral axis from section and reinforcement given.
- (ii) Find the position of the critical $N.A.$ from known permissible stresses of concrete and steel.

$$x = \frac{1}{1 + \frac{\sigma_{st}}{m \cdot \sigma_{cbc}}} \cdot d$$

- (iii) Check if (i) > (ii)- the section is over-reinforced

(i) < (ii)- the section is under-reinforced

- (iv) Calculate M from relation

$$M = b \cdot x \cdot \frac{1}{2} \cdot \sigma_{cbc} \cdot \left(d - \frac{x}{3} \right) \text{ for over-reinforced section}$$

and $M = \sigma_{st} \cdot A_s \cdot \left(d - \frac{x}{3} \right)$ for under-reinforced section.

- (v) If the effective span and the support conditions of the beam are known, the load carrying capacity can be computed.

(D) To Check The Stresses Developed In Concrete And Steel

The section, reinforcement and bending moment are given.

Steps to be followed:

- (i) Find the position of *N.A.* using the following relation.

$$b \cdot \frac{x^2}{2} = m \cdot A_s \cdot (d - x)$$

- (ii) Determine lever arm, $z = d - \frac{x}{3}$

- (iii) $B.M. = \sigma_{st} \cdot A_s \cdot z$ is used to find out the actual stress in steel σ_{sa} .

- (iv) To compute the actual stress in concrete σ_{cba} , use the following relation.

$$BM = \frac{\sigma_{cba}}{2} \cdot b \cdot x \cdot z$$

Doubly Reinforced Beam Sections by Working Stress Method

Very frequently it becomes essential for a section to carry bending moment more than it can resist as a balanced section. Such a situation is encountered when the dimensions of the cross section are limited because of structural, head room or architectural reasons. Although a balanced section is the most economical section but because of limitations of size, section has to be sometimes over-reinforced by providing extra reinforcement on tension face than that required for a balanced section and also some reinforcement on compression face. Such sections reinforced both in tension and compression are also known as “Doubly Reinforced Sections”. In some loading cases reversal of stresses in the section take place (this happens when wind blows in opposite directions at different timings), the reinforcement is required on both faces.

MOMENT OF RESISTANCE OF DOUBLY REINFORCED SECTIONS

Consider a rectangular section reinforced on tension as well as compression faces as shown in Fig.2.4 (a-c)

Let b = width of section,

d = effective depth of section,

D = overall depth of section,

d' = cover to centre of compressive steel,

M = Bending moment or total moment of resistance,

M_{bal} = Moment of resistance of a balanced section with tension reinforcement,

A_{st} = Total area of tensile steel,

A_{st1} = Area of tensile steel required to develop M_{bal}

A_{st2} = Area of tensile steel required to develop M_2

A_{sc} = Area of compression steel,

σ_{st} = Stress in steel, and

σ_{sc} = Stress in compressive steel

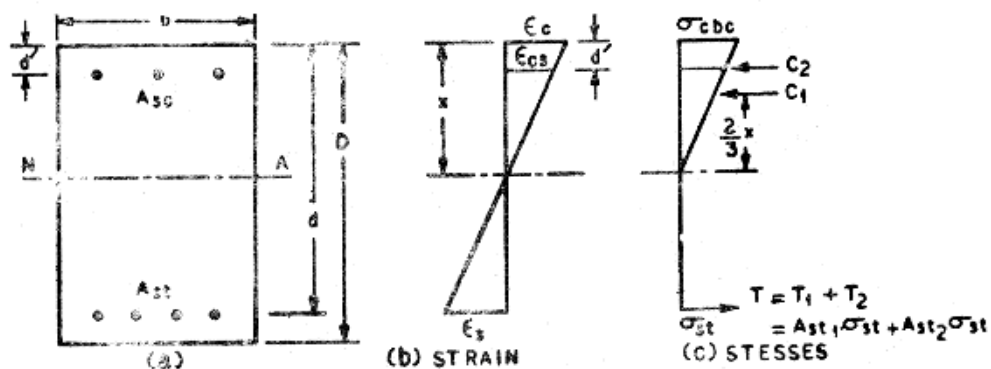

Fig.2.4 (a-c)

Since strains are proportional to the distance from $N.A.$,

$$\frac{\text{Strain in top fibre of concrete}}{\text{Strain in Compression Steel}} = \frac{x}{x - d'}$$

$$\frac{\sigma_{cbc}/E_c}{\sigma_{sc}/E_s} = \frac{x}{x - d'}$$

$$\frac{\sigma_{cbc}}{\sigma_{sc}} \cdot \frac{E_s}{E_c} = \frac{x}{x - d'}$$

$$\sigma_{sc} = \sigma_{cbc} \cdot \frac{x}{x - d'} \cdot m$$

Since $\sigma_{cbc} \cdot \frac{x-d'}{x}$ is the stress in concrete at the level of compression steel, it can be denoted as

$$\sigma'_{cbc}$$

$$\therefore \sigma_{sc} = m \cdot \sigma'_{cbc}$$

As per the provisions of IS:456-2000 Code, the permissible compressive stress in bars, in a beam or slab when compressive resistance of the concrete is taken into account, can be taken as 1.5m times the compressive stress in surrounding concrete ($1.5m \sigma'_{cbc}$) or permissible stress in steel in compression (σ_{sc}) whichever is less.

$$\sigma_{sc} = 1.5m \sigma'_{cbc}$$

Total equivalent concrete area resisting compression

$$(x \cdot b - A_{sc}) + 1.5m A_{sc} = x \cdot b + (1.5m - 1)A_{sc}$$

Taking moment about centre of tensile steel

$$\text{Moment of resistance } M = C_1 \cdot (d - x/3) + C_2 \cdot (d - d')$$

Where C_1 = total compressive force in concrete,

C_2 = total compressive force in compression steel,

$$\begin{aligned} M &= b \cdot x \cdot \frac{\sigma_{cbc}}{2} \cdot \left(d - \frac{x}{3}\right) + (1.5m - 1)A_{sc} \cdot \sigma_{sc} \cdot \frac{x - d'}{x} \cdot (d - d') = Q \cdot b \cdot d^2 + (1.5m - 1)A_{sc} \cdot \sigma_{sc} \cdot \frac{x - d'}{x} \cdot (d - d') \\ &= M_1 + M_2 \end{aligned}$$

Where M_1 = Moment of resistance of the balanced section = M_{bal}

M_2 = Moment of resistance of the compression steel

$$\text{Area of tension steel} = A_{st1} = \frac{M_1}{\sigma_{st} \cdot j \cdot d}$$

$$\text{Area of tension steel equivalent to compression steel} = A_{st2} = \frac{M_2}{\sigma_{st} (d - d')}$$

Thus the total tensile steel A_{st} shall be:

$$\therefore A_{st} = A_{st1} + A_{st2}$$

The area of compression steel can be obtained as

$$(1.5m - 1)A_{sc} (x - d') = mA_{st2} \cdot (d - x)$$

Design Concept of T-Beam

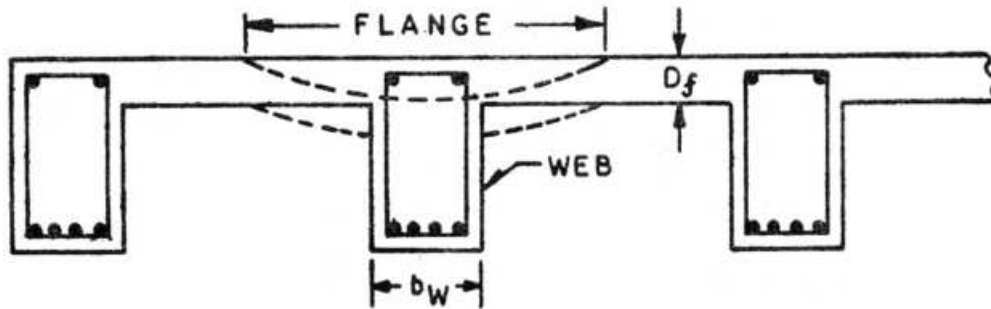

Fig.2.5

Flanged beam sections comprise T-beams and L-beams where the slabs and beams are cast monolithically having no distinction between beams and slabs. Consequently the beams and slabs are so closely tied that when the beam deflects under applied loads it drags along with it a portion of the slab also as shown in Fig.2.5. This portion of the slab assists in resisting the effects of the loads and is called the 'flange' of the T-beams. For design of such beams, the profile is similar to a T-section for intermediate beams. The portion of the beam below the slab is called 'web' or 'Rib'. A slab which is assumed to act as flange of a T-beam shall satisfy the following conditions:

- (a) The slab shall be cast integrally with the web or the web and the slab shall be effectively bonded together in any other manner; and
- (b) If the main reinforcement of the slab is parallel to the beam, transverse reinforcement shall be provided as shown in Fig.2.6, such reinforcement shall not be less than 60% of the main reinforcement at mid-span of the slab.

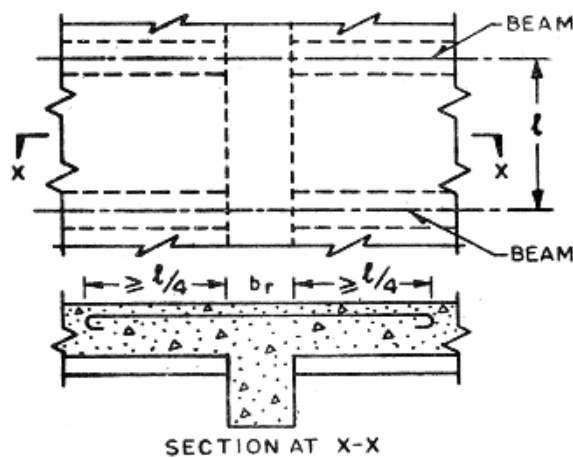

Fig.2.6

CHAPTER- 3

LIMIT STATE METHOD

SAFETY AND SERVICEABILITY REQUIREMENTS

In the method of design based on limit state concept, the structure shall be designed to withstand safely all loads liable to act on it throughout its life; it shall also satisfy the serviceability requirements, such as limitations on deflection and cracking. The acceptable limit for the safety and serviceability requirements before failure occurs is called a 'limit state'. The aim of design is to achieve acceptable probabilities that the structure will not become unfit for the use for which it is intended that it will not reach a limit state.

All relevant limit states shall be considered in design to ensure an adequate degree of safety and serviceability. In general, the structure shall be designed on the basis of the most critical limit state and shall be checked for other limit states.

For ensuring the above objective, the design should be based on characteristic values for material strengths and applied loads, which take into account the variations in the material strengths and in the loads to be supported. The characteristic values should be based on statistical data if available; where such data are not available they should be based on experience. The 'design values' are derived from the characteristic values through the use of partial safety factors, one for material strengths and the other for loads. In the absence of special considerations these factors should have the values given in 36 according to the material, the type of loading and the limit state being considered.

Limit State of Collapse

The limit state of collapse of the structure or part of the structure could be assessed from rupture of one or more critical sections and from buckling due to elastic or plastic instability (including the effects of sway where appropriate) or overturning. The resistance to bending, shear, torsion and axial loads at every section shall not be less than the appropriate value at that section produced by the probable most unfavourable combination of loads on the structure using the appropriate partial safety factors.

Limit State Design

For ensuring the design objectives, the design should be based on characteristic values for material strengths and applied loads (actions), which take into account the probability of variations in the material strengths and in the loads to be supported. The characteristic values should be based on statistical data, if available. Where such data is not available, they should be based on experience. The design values are derived from the characteristic values through the use of partial safety factors, both for material strengths and for loads. In the absence of special considerations, these factors should have the values given in this section according to the material, the type of load and the limit state being considered. The reliability of design is ensured by requiring that

$$\text{Design Action} \leq \text{Design Strength.}$$

Limit states are the states beyond which the structure no longer satisfies the performance requirements specified. The limit states are classified as

- a) Limit state of strength
- b) Limit state of serviceability

a) The limit state of strength are those associated with failures (or imminent failure), under the action of probable and most unfavorable combination of loads on the structure using the appropriate partial safety factors, which may endanger the safety of life and property. The limit state of strength includes:

- a) Loss of equilibrium of the structure as a whole or any of its parts or components.
- b) Loss of stability of the structure (including the effect of sway where appropriate and overturning) or any of its parts including supports and foundations.
- c) Failure by excessive deformation, rupture of the structure or any of its parts or components.
- d) Fracture due to fatigue.
- e) Brittle fracture.

b) The limit state of serviceability include

- a) Deformation and deflections, which may adversely affect the appearance or, effective, use of the structure or may cause improper functioning of equipment or services or may cause damages to finishes and non-structural members.
- b) Vibrations in the structure or any of its components causing discomfort to people, damages to the structure, its contents or which may limit its functional effectiveness. Special consideration shall be given to floor vibration systems susceptible to vibration, such as large open floor areas free of partitions to ensure that such vibrations is acceptable for the intended use and occupancy.
- c) Repairable damage due to fatigue.
- d) Corrosion and durability.

Limit States of Serviceability

To satisfy the limit state of serviceability the deflection and cracking in the structure shall not be excessive. This limit state corresponds to deflection and cracking.

Deflection

The deflection of a structure or part shall not adversely affect the appearance or efficiency of the structure or finishes or partitions.

Cracking

Cracking of concrete should not adversely affect the appearance or durability of the structure; the acceptable limits of cracking would vary with the type of structure and environment. The actual width of cracks will vary between the wide limits and predictions of absolute maximum width are not possible. The surface width of cracks should not exceed 0.3mm.

In members where cracking in the tensile zone is harmful either because they are exposed to the effects of the weather or continuously exposed to moisture or in contact soil or ground water, an upper limit of 0.2 mm is suggested for the maximum width of cracks. For particularly aggressive environment, such as the 'severe' category, the assessed surface width of cracks should not in general, exceed 0.1 mm.

CHARACTERISTIC AND DESIGN VALUES AND PARTIAL SAFETY FACTORS

1. Characteristic Strength of Materials

Characteristic strength means that value of the strength of the material below which not more than 5 percent of the test results are expected to fall and is denoted by f . The characteristic strength of concrete (f_{ck}) is as per the mix of concrete. The characteristic strength of steel (f_y) is the minimum stress or 0.2 percent of proof stress.

2. Characteristic Loads

Characteristic load means that value of load which has a 95 percent probability of not being exceeded during the life of the structure. Since data are not available to express loads in statistical terms, for the purpose of this standard, dead loads given in IS 875 (Part 1), imposed loads given in IS 875 (Part 2), wind loads given in IS 875 (Part 3), snow load as given in IS 875 (Part 4) and seismic forces given in IS 1893-2002(part-I) shall be assumed as the characteristic loads.

Design Values

Materials

The design strength of the materials f_d is given by

$$f_d = \frac{f}{\gamma_m}$$

where

f = characteristic strength of the material

γ_m = partial safety factor appropriate to the material and the limit state being considered.

Load

The design load, F , is given by

$$f_d = \frac{F}{\gamma_f}$$

Where, F = characteristic load

and γ_f = partial safety factor appropriate to the nature of loading and the limit state being considered.

Consequences of Attaining Limit State

Where the consequences of a structure attaining a limit state are of a serious nature such as huge loss of life and disruption of the economy, higher values for γ_f and γ_m than those given under 36.4.1 and 36.4.2 may be applied.

Partial Safety Factors:

1. Partial Safety Factor γ_f for Loads

Sr. No.	Load Combination	Ultimate Limit State	Serviceability Limit State
1	DL + LL	1.5 (DL + LL)	DL + LL
2	DL + WL i) DL contribute to stability ii) DL assists overturning	0.9 DL + 1.5 WL 1.5 (DL + WL)	DL + WL DL + WL
3	DL + LL + WL	1.2 (DL + LL + WL)	DL + 0.8 LL + 0.8 WL

2. Partial Safety Factor γ_m for Material Strength

Sr. No.	Material	Ultimate Limit State	Serviceability Limit State
1	Concrete	1.50	$E_c = 5000\sqrt{f_{ck}}$ MPa
2	Steel	1.15	$E_s = 2 \times 10^5$ MPa

When assessing the strength of a structure or structural member for the limit state of collapse, the values of partial safety factor, should be taken as 1.5 for concrete and 1.15 for steel.

LIMIT STATE OF COLLAPSE: FLEXURE

Assumptions for Limit State of Collapse (Flexure):

- 1) Plane section normal to the axis remains plane even after bending. i.e. strain at any point on the cross section is directly proportional to the distance from the N.A.
- 2) Maximum strain in concrete at the outer most compression fibre is taken as 0.0035 in bending.
- 3) The relationship between the compressive stress distribution in concrete and the strain in concrete may be assumed to be rectangle, trapezoid, parabola or any other shape which results in prediction of strength in substantial agreement with the results of test. An acceptable stress strain curve is as shown below.

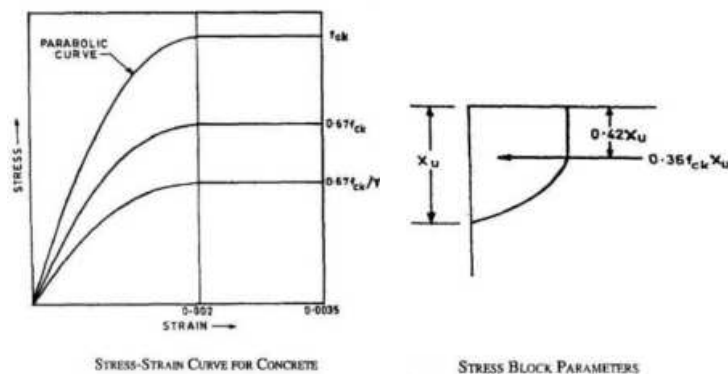

For design purposes, the compressive strength of concrete in the structure shall be assumed to be 0.67 times the characteristic strength. The partial safety factor $\gamma_m = 1.5$ shall be applied in addition to this.

NOTE - For the above stress-strain curve the design stress block parameters are as follows:

Area of stress block = $0.36.f_{ck}.x_u$

Depth of centre of compressive force = $0.42x_u$ from the extreme fibre in compression

Where

f_{ck} = characteristic compressive strength of concrete, and

x_u = depth of neutral axis.

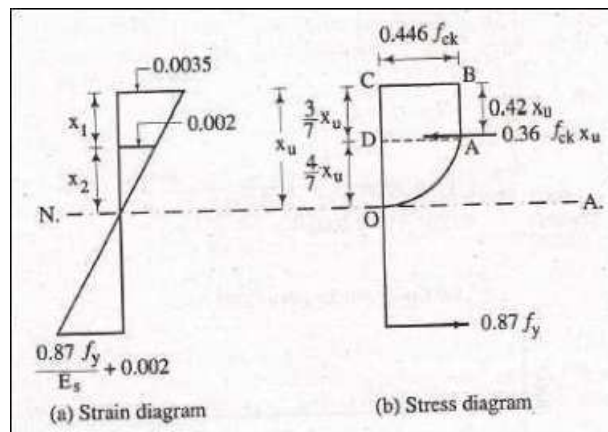

- 4) the tensile strength of the concrete is ignored.
- 5) the stresses in the reinforcement are derived from representative stress – strain curve for the type of steel used.

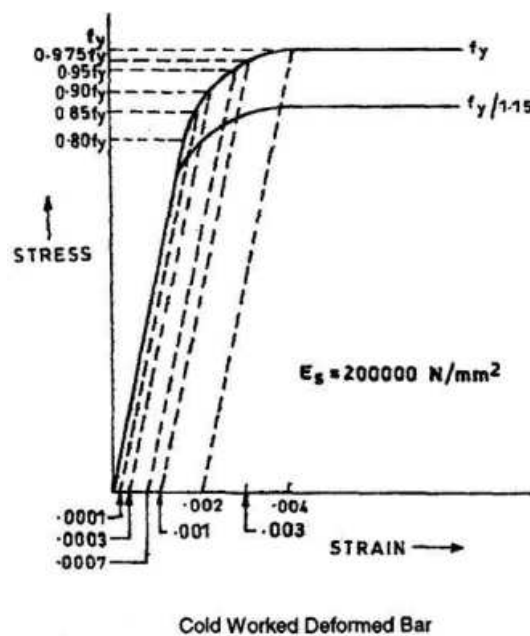

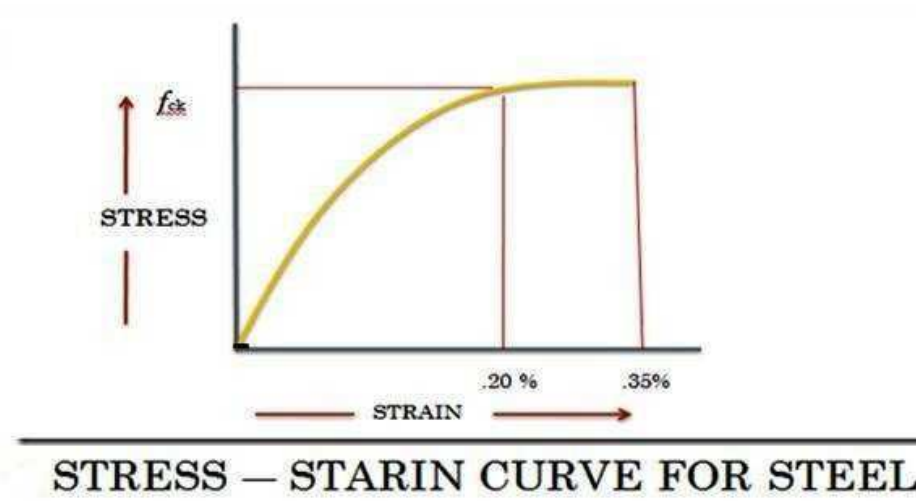

- 6) the maximum strain in tension reinforcement in the section at failure shall not be less than

$$\frac{f_y}{1.15E_s} + 0.002 = \frac{0.87f_y}{E_s} + 0.002$$

CHAPTER 4

LIMIT STATES OF COLLAPSE OF SINGLE REINFORCED MEMBERS IN BENDING

Limit state method of design

- The object of the design based on the limit state concept is to achieve an acceptable probability, that a structure will not become unsuitable in its lifetime for the use for which it is intended, i.e. It will not reach a limit state
 - A structure with appropriate degree of reliability should be able to withstand safely.
 - All loads, that are reliable to act on it throughout its life and it should also satisfy the serviceability requirements, such as limitation on deflection and cracking.
 - It should also be able to maintain the required structural integrity, during and after accident, such as fires, explosion & local failure. i.e. limit state must be considered in design to ensure an adequate degree of safety and serviceability
 - The most important of these limit states, which must be examined in design are as follows
 - Flexure
 - Compression
 - Shear
 - Torsion
- This state corresponds to the maximum load carrying capacity.

Types of reinforced concrete beams

- a) Singly reinforced beam
- b) Doubly reinforced beam
- c) Singly or Doubly reinforced flanged beams

Singly reinforced beam

In singly reinforced simply supported beams or slabs reinforcing steel bars are placed near the bottom of the beam or slabs where they are most effective in resisting the tensile stresses.

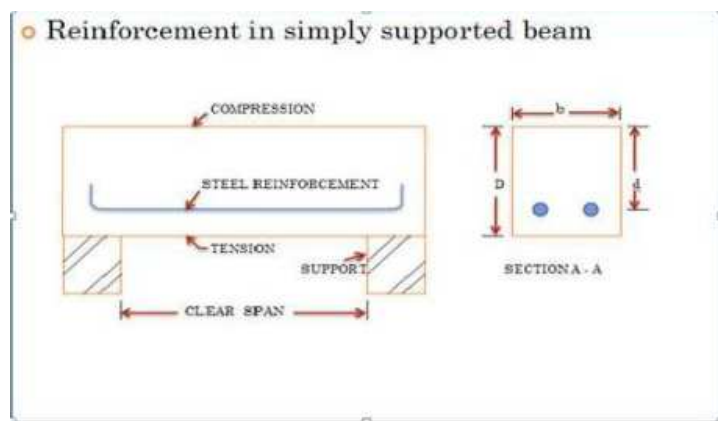

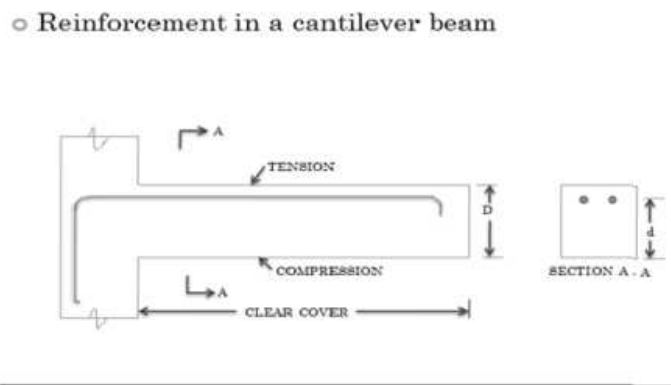

TYPES OF BEAM SECTIONS

Section in which, tension steel also reaches yield strain simultaneously as the concrete reaches the failure strain in bending are called, '**Balanced Section**'.

Section in which, tension steel also reaches yield strain at loads lower than the load at which concrete reaches the failure strain in bending are called, '**Under Reinforced Section**'.

Section in which, tension steel also reaches yield strain at loads higher than the load at which concrete reaches the failure strain in bending are called, '**Over Reinforced Section**'.

Sr. No.	Types of Problems	Data Given	Data Determine								
1.	Identify the type of section, balance, under reinforced or over reinforced	Grade of Concrete & Steel, Size of beam & Reinforcement provided	<p>If $\frac{X_u}{d} = \frac{X_{u \max}}{d} \Rightarrow$ Balanced</p> <p>If $\frac{X_u}{d} < \frac{X_{u \max}}{d} \Rightarrow$ Under Reinforced</p> <p>If $\frac{X_u}{d} > \frac{X_{u \max}}{d} \Rightarrow$ Over Reinforced</p> $\frac{X_u}{d} = \frac{0.87 f_y A_{st}}{0.36 b d f_{ck}}$ <table style="margin-left: auto; margin-right: auto;"> <tr> <td>f_y</td> <td>$\frac{X_{u \max}}{d}$</td> </tr> <tr> <td>250</td> <td>0.53</td> </tr> <tr> <td>415</td> <td>0.48</td> </tr> <tr> <td>500</td> <td>0.46</td> </tr> </table>	f_y	$\frac{X_{u \max}}{d}$	250	0.53	415	0.48	500	0.46
f_y	$\frac{X_{u \max}}{d}$										
250	0.53										
415	0.48										
500	0.46										

2	Calculate Moment of Resistance	Grade of Concrete & Steel, Size of beam & Reinforcement Provided	<p>1) If $\frac{x_u}{d} = \frac{x_{u,max}}{d}$, <i>balanced</i></p> $M.R = M_u = 0.36 \cdot \frac{x_{u,max}}{d} (1 - 0.42 \frac{x_{u,max}}{d}) b \cdot d^2 \cdot f_{ck}$ <p>2) If $\frac{x_u}{d} < \frac{x_{u,max}}{d}$ Under Reinforced</p> <p>M.R=M_u=</p> $0.87 f_y \cdot A_{st} \cdot d (1 - \frac{A_{st} \cdot f_y}{b \cdot d \cdot f_{ck}}) \text{ or } M.R = 0.87 f_y \cdot A_{st} \cdot d (1 - 0.42 \frac{x_u}{d})$ <p>3) If</p> $\frac{x_u}{d} > \frac{x_{u,max}}{d} \Rightarrow \text{over reinforced, Revise the depth}$
3	Design the beam. Find out the depth of Beam D & Reinforcement required A _{st} .	Grade of Concrete & Steel, width of beam & Bending Moment or loading on the beam with the span of the beam Reinforcement Provided	<p>We have to design the beam as a ‘Balanced Design’.</p> <p>For finding ‘d’ effective depth use the equation;</p> $M.R = M_u = 0.36 \cdot \frac{x_{u,max}}{d} (1 - 0.42 \frac{x_{u,max}}{d}) b \cdot d^2 \cdot f_{ck}$ <p>For finding A_{st} use the equation</p> $0.87 f_y \cdot A_{st} \cdot d (1 - \frac{A_{st} \cdot f_y}{b \cdot d \cdot f_{ck}}) \text{ or } M.R = 0.87 f_y \cdot A_{st} \cdot d (1 - 0.42 \frac{x_u}{d})$

Where

d = effective depth of beam in mm.

b = width of beam in mm

x_u = depth of actual neutral axis in mm from extreme compression fibre.

x_{u,max} = depth of critical neutral axis in mm from extreme compression fibre.

A_{st} = area of tensile reinforcement

f_{ck} = characteristic strength of concrete in MPa.

f_y = characteristic strength of steel in MPa.

M_{u,lim} = Limiting Moment of Resistance of a section without compression reinforcement

Doubly Reinforced Section or sections with Compression Reinforcement

Doubly Reinforced Section sections are adopted when the dimensions of the beam have been predetermined from other considerations and the design moment exceeds the moment of resistance of a singly reinforced section. The additional moment of resistance is carried by providing compression reinforcement and additional reinforcement in tension zone. The moment of resistance of a doubly reinforced section is the sum of the limiting moment of resistance $M_{u,lim}$ of a single reinforced section and the additional moment of resistance M_{u2} .

$$M_{u2} = M_u - M_{u,lim}$$

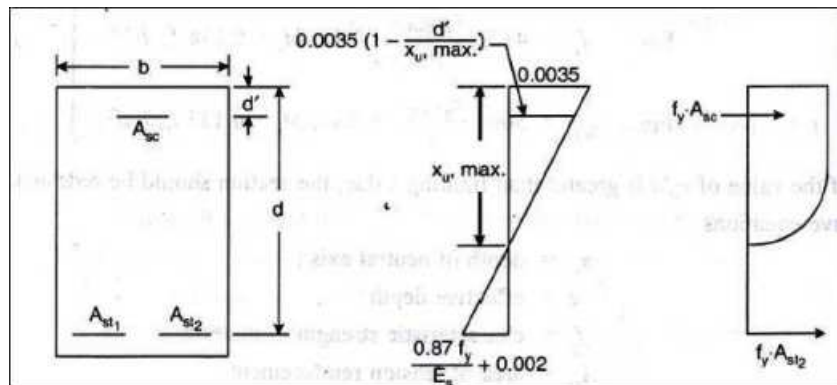

The lever arm for the additional moment of resistance is equal to the distance between the centroids of tension and compression reinforcement, $(d - d')$.

$$M_{u2} = 0.87 f_y A_{st2} (d - d') = A_{sc} (f_{sc} - f_{cc}) (d - d')$$

Where : A_{st2} = Area of additional tensile reinforcement

A_{sc} = Area of compression reinforcement

f_{sc} = Stress in compression reinforcement

f_{cc} = Compressive stress in concrete at the level of compression reinforcement

Since the additional reinforcement is balanced by the additional compressive force.

$$A_{sc} (f_{sc} - f_{cc}) = 0.87 f_y A_{st2}$$

The strain at level of compression reinforcement is $0.0035 (1 - \frac{d'}{x_{u,max}})$

Total area of reinforcement shall be obtained by

$$A_{st} = A_{st1} + A_{st2}$$

A_{st1} = Area of reinforcement for a singly reinforced section for $M_{u,lim}$

$$A_{st2} = \frac{A_{sc} (f_{sc} - f_{cc})}{0.87 f_y}$$

EXAMPLE 4.1

Calculate the area of steel of grade Fe 415 required for section of 250mm wide and overall depth 500mm with effective cover 40mm in M20, if the limit state of moment be carried by the section is

- a) 100 KN b) 146 KN c) 200KN

SOLUTION:

$$\text{For } f_y = 415 \text{ N/mm}^2, \frac{x_{u,\max}}{d} = 0.48$$

$$\begin{aligned} M_{u,\lim} &= 0.36 \cdot \frac{x_{u,\max}}{d} (1 - 0.42 \frac{x_{u,\max}}{d}) b \cdot d^2 \cdot f_{ck} \\ &= 0.36 \times 0.48 (1 - 0.42 \times 0.48) \times 250 \times 460^2 \times 20 \\ &= 146 \times 10^6 \text{ N.mm} \end{aligned}$$

- a) For $M_u = 100 \text{ KN.m} < 146 \text{ KN.m}$

Area of steel required is obtained from , $M_u = 0.87 f_y A_{st} d (1 - \frac{A_{st} f_y}{b \cdot d \cdot f_{ck}})$

$$100 \times 10^6 = 0.87 \times 415 \times A_{st} \times 460 (1 - \frac{A_{st} \times 415}{250 \times 460 \times 20})$$

$$A_{st} = 686 \text{ or } 4850 \text{ mm}^2, \text{ taking minimum steel } 686 \text{ mm}^2$$

- b) $M_u = 146 \text{ KN.m} = M_{u,\lim} = 146 \text{ KN.m}$

$$x_u = x_{u,\max}$$

Area of tension reinforcement required

$$\frac{x_{u,\max}}{d} = \frac{0.87 f_y A_{st}}{0.36 b \cdot d \cdot f_{ck}}$$

$$A_{st} = \frac{0.48 \times 0.36 \times 20 \times 250 \times 460}{0.87 \times 415} = 1100 \text{ mm}^2$$

- c) $M_u = 200 \text{ KN.m} > M_{u,\lim} = 146 \text{ KN.m}$

Reinforcement is to be provided in the compression zone also along with the reinforcement in tension zone.

$$M_u = M_{u,\lim} = f_{sc} \cdot A_{sc} (d - d')$$

$$f_{sc} \text{ is stress corresponding to strain of } \frac{0.0035(x_{u,\max} - d')}{x_{u,\lim}} = \frac{0.0035(0.48 \times 460 - 40)}{0.48 \times 460} = 0.002866$$

$$f_{sc} = 360.8 \text{ N/mm}^2$$

$$(200 - 146) \times 10^6 = 360.8 \cdot A_{sc}(460 - 40)$$

$$A_{sc} = 356 \text{ mm}^2$$

A_{st1} = Area of tension reinforcement corresponding to $M_{u,\lim}$

$$146 \times 10^6 = 0.87 \times 460 \times 415 A_{st1} \left(1 - \frac{A_{st1} \times 415}{250 \times 460 \times 20}\right)$$

$$A_{st1} = 1094 \text{ mm}^2$$

$$A_{st2} = A_{sc} \cdot f_{sc} / 0.87 \times 415 = 356 \text{ mm}^2$$

$$A_{st} = A_{st1} + A_{st2} = 1094 + 356 = 1450 \text{ mm}^2$$

EXAMPLE: 4.2

Design a rectangular beam which carries a maximum limiting bending moment of 65 KN.m. Use M20 and Fe 415 as reinforcement.

At balanced failure condition

$$M_u = M_{u,\lim}$$

$$M_{u,\lim} = 0.36 \cdot \frac{x_{u,\max}}{d} \left(1 - 0.42 \frac{x_{u,\max}}{d}\right) b \cdot d^2 \cdot f_{ck}$$

$$\begin{aligned} M_{u,\lim} &= 0.36 \times 0.48 \times 20 (1 - 0.42 \times 0.48) b d^2 \\ &= 2.759 b d^2 \end{aligned}$$

Assuming width of beam as 250 mm

$$d = \sqrt{\frac{65 \times 10^6}{2.759 \times 250}} = 307 \text{ mm}$$

Area of reinforcement

$$\frac{x_{u,\max}}{d} = \frac{0.87 f_y A_{st}}{0.36 b d f_{ck}}$$

$$0.48 = \frac{0.87 \times 415 \times A_{st}}{0.36 \times 20 \times 250 \times 307}$$

$$A_{st} = 734.66 \text{ mm}^2$$

EXAMPLE: 4.3

Find out the factored moment of resistance of a beam section 300mm wide X 450mm effective depth reinforced with 2 X 20mm diameter bars as compression reinforcement at an effective cover of 50mm and 4 X 25mm diameter bars as tension reinforcement. The materials are M20 grade concrete and Fe 415 HYSD bars.

Solution:

Given;

$$\text{Width} = b = 300\text{mm}$$

$$\text{Effective depth} = d = 450\text{mm}$$

$$\text{Cover to compression reinforcement} = d' = 50\text{mm}$$

$$\frac{d}{d'} = \frac{50}{450} = 0.11, \text{ next higher value } 0.15 \text{ may be adopted.}$$

$$A_{sc} = \text{area compression reinforcement} = 2 \pi 16^2 = 628\text{mm}^2$$

$$A_{st} = \text{area of reinforcement in tension} = 4 \times \pi 25^2 = 1964\text{mm}^2$$

$$f_{sc} = \text{stress in compression steel} = 342 \text{ N/mm}^2$$

Equating total force

$$0.36 f_{ck} \cdot b \cdot x_u + f_{sc} \cdot A_{sc} = 0.87 f_y \cdot A_{st}$$

$$0.36 \times 20 \times 300 x_u + 628 \times 342 = 0.87 \times 415 \times 1964$$

$$x_u = 228.85\text{mm}$$

But $x_{u,\max} = 0.48d$ for Fe415

$$x_{u,\max} = 0.48 \times 450 = 216\text{mm}$$

So $x_u > x_{u,\max} \Rightarrow$ over reinforced

The moment of resistance can be found out by taking moments of compressive forces about centroid of tensile reinforcement.

$$M_u = 2160x_u(450 - 0.42x_u) + 214776(450 - 50) \times 10^{-6}$$

$$\text{Putting } x_u = 216\text{mm}$$

$$M_u = 253.54 \text{ KN.m}$$

BEHAVIORS OF 'T' AND 'L' BEAMS (FLANGED BEAM)

A 'T' beam or 'L' beam can be considered as a rectangular beam with dimensions $b_w \cdot D$ plus a flange of size $(b_f - b_w) \times D_f$. It is shown in the figure beam (a) is equivalent to beam (b) + beam (c).

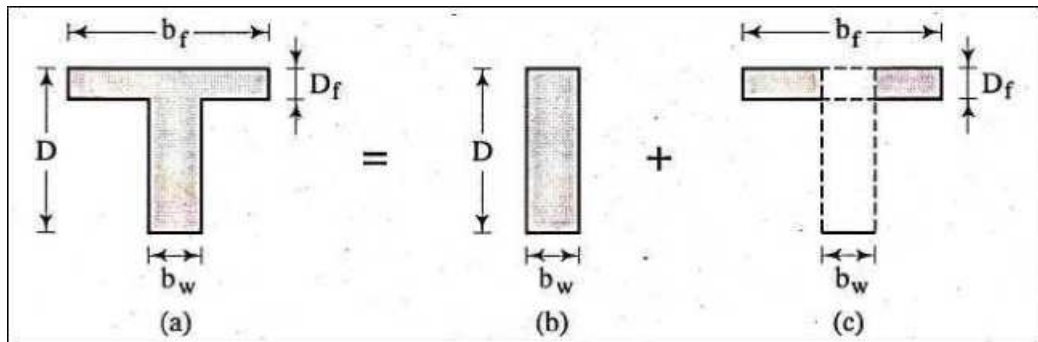

The flanged beam analysis and design are analogous to doubly reinforced rectangular beam. In doubly reinforced beams additional compressive is provided by adding reinforcement in compression zone, whereas in flanged beams, this is provided by the slab concrete, where the spanning of the slab is perpendicular to that of beam and slab is in compression zone.

If the spanning of the slab is parallel to that of the beam, some portion of slab can be made to span in the direction perpendicular to that of the beam by adding some reinforcement in the slab.

A flanged beam can be also doubly reinforced.

The moment of resistance of a T beam is sum of the moment of resistance of beam (a) is the sum moment of resistance of beam (b) and moment of resistance of beam (c)

CHAPTER-5

LIMIT STATE OF COLLAPSE IN SHEAR (Design of Shear by LSM)

5.1. SHEAR STRESS IN REINFORCED CONCRETE BEAMS:-

When a beam is loaded with transverse loads the Bending Moment(BM) varies from section to section. Shearing stresses in beams are caused by this variation of BM in the beam span. Due to the variation of BM at two sections distance dx apart, there are unequal bending stresses at the same fibre. This inequality of bending stresses produces a tendency in each horizontal fibre to slide over adjacent horizontal fibre causing horizontal shear stress, which is accompanied by complimentary shear stress in vertical direction.

SHEAR CRACKS IN BEAMS:-

Under the transverse loading , at any section of the beam, there exists both Bending Moment(BM) and Shear Force (V). Depending upon the ratio of Bending Moment(BM) to Shear Force(V) at different sections, there may be three regions of shear cracks in the beam as follows.

- (a) Region I : Region of flexure Cracks.
- (b) Region II : Region of flexure shear Cracks.
- (c) Region III : Region of web shear Cracks or diagonal tension cracks.

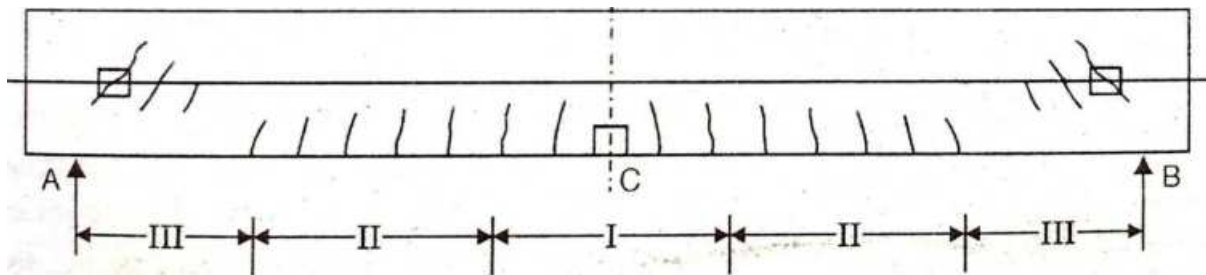

Fig-5.2.1 DIFFERENT REGION OF CRACKS IN BEAMS

- (a) **Region I : Region of flexure Cracks.**

This region normally occurs adjacent to mid-span where BM is large and shear force is either zero or very small. The principal planes are perpendicular to beam axis. When the principal tensile stress reaches the tensile strength of the concrete (which is quite low) tensile cracks develop vertically. The cracks are known as flexural cracks resulting primarily due to flexure.

(b) Region II : Region of flexure shear Cracks. These regions are near the quarter span, to both the sides, where BM is considerable and at the same time Shear force is significant. The cracks in this region are initiated at the tension face, travel vertically (due to flexure) and gradually tend to develop in the inclined direction towards the Nutral Axis(N.A.), as the shear stress goes on increasing towards the N.A. Since the cracks develop under the combined action of BM and Shear, these cracks are known as flexure- shear cracks.

(c) Region II : Region of web shear Cracks or diagonal tension cracks.

This regions are adjacent to each support of the beam where S.F is predominant. Since Shear stress is maximum at the N.A., inclined cracks starts developing at the N.A. along the diagonal of an element subject to the action of pure shear. Hence these cracks known as diagonal tension cracks or web-shear cracks.

MECHANISM OF SHEAR TRANSFER IN REINFORCE CONCRETE BEAM WITHOUT SHEAR.

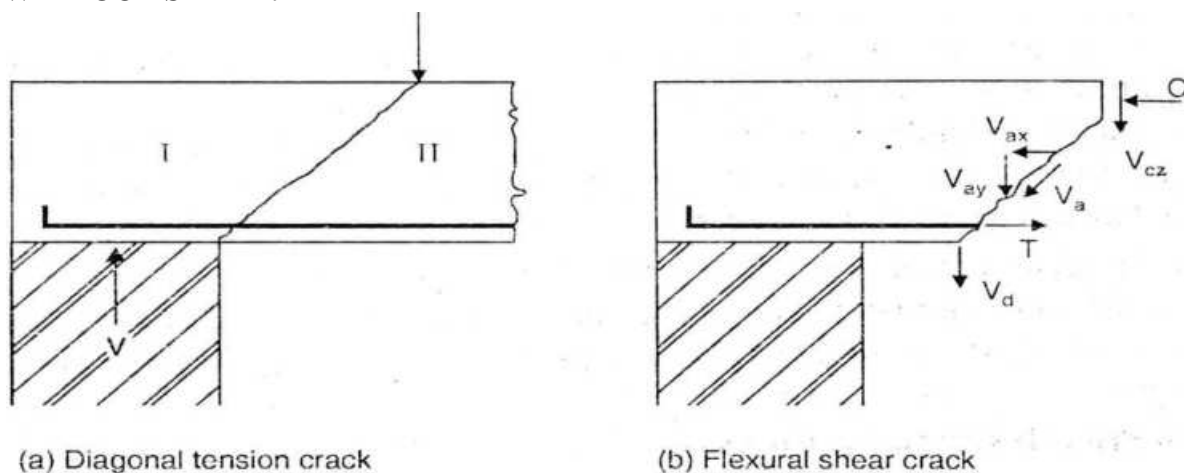

Fig- 5.3.1

Shear is transferred between two adjacent planes in a R C beam by the following mechanism.

- Shear resistance V_{cz} of the uncracked portion of concrete.
- Vertical Component V_{ay} of the interface shear or aggregate interlock force V_a , and
- Dowel force V_d in the tension reinforcement, due to dowel action.

Thus $V = V_{cz} + V_{ay} + V_d$.

The relative contribution of each of the above three mechanism depend upon the stage of loading and extent of cracking. In the initial stage before the flexural cracking starts, the entire shear is resisted by the shear resistance of the concrete (i.e $V = V_{cz}$).

As the flexural cracking starts, the interface shear comes into action resulting in the redistribution of stresses. Further extension of flexural cracks results in sharing the shear by the dowel force V_d of the tension reinforcement. Thus at the final stage of collapse , the shear is transferred by the shear is born by all the three mechanism expressed by the equation above.

MODES OF SHEAR FAILURE

The shear Failure of a R C beam, without shear reinforcement is governed by a_v/d , ratio. A beam may experience following types of shear failure.

1. Case I : $a_v/d < 1$: Splitting or compression failure.
2. Case II : $1 < a_v/d < 2.8$: Shear compression or shear tension failure.
3. Case III : $2.8 < a_v/d < 6$: Diagonal tension failure.
4. Case-IV : $a_v/d > 6$: Flexure failure

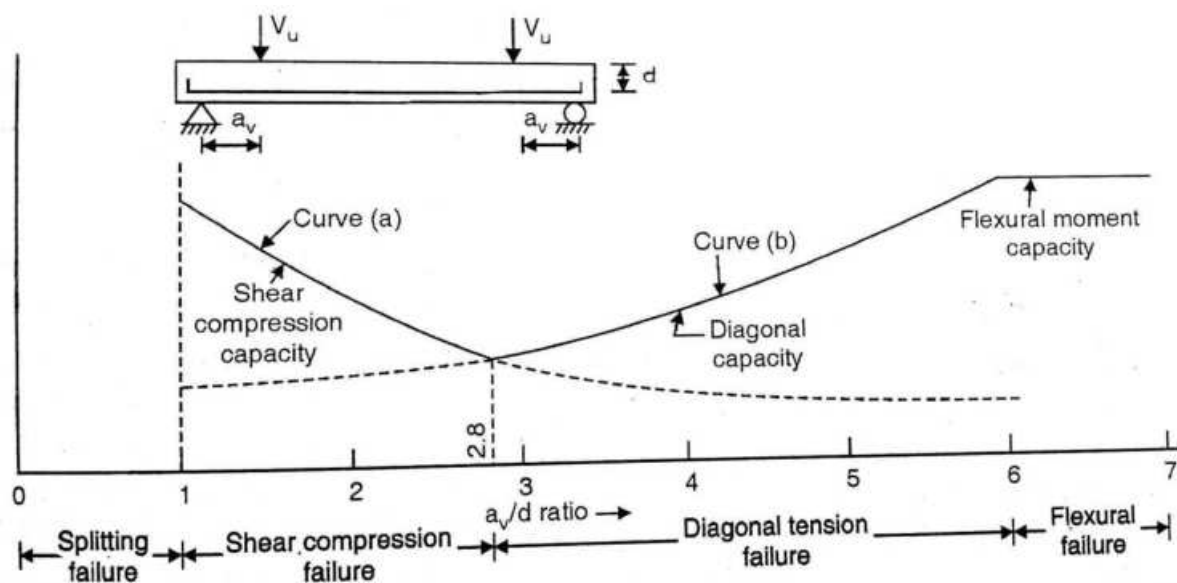

Fig – 5.4.1. EFFECT OF a_v/d ON SHEAR STRENGTH OF R C BEAM

CASE I : $a_v / d < 1$ (Deep Beams) : Splitting or compression failure:

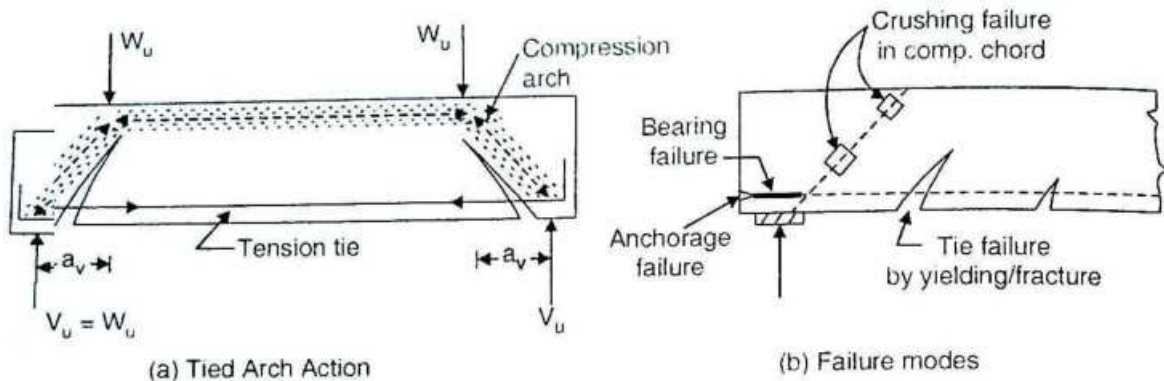

Fig – 5.4.2. CASE I : $a_v / d < 1$ (DEEP BEAMS)

This case corresponds to a deep beam without shear reinforcements where the inclined cracking transforms the beam into a tied arch (Fig-a). The load is carried by (i) direct compression in the concrete between the load and reaction point by crossing of concrete and by (ii) tension in the longitudinal steel by yielding or fracture or anchorage failure or bearing failure.

CASE II : $1 < a_v / d < 2.8$: Shear compression or shear tension failure.

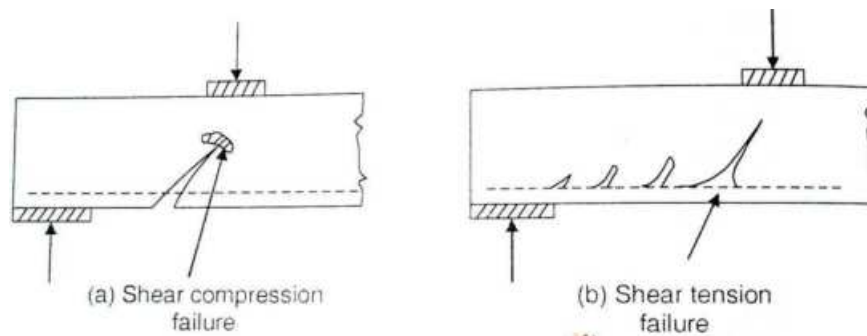

Fig- 5.4.3 CASE II : $1 < a_v / d < 2.8$

This case is common in short beams with a_v / d ratio between 1 to 2.8, where failure is initiated by an inclined crack – more commonly a flexural shear crack. Fig-a shows the shear compression failure due to vertical compressive stresses developed in the vicinity of the load. Similarly the vertical compressive stress over the reaction limits the bond splitting and diagonal cracking along the steel. The crack extends towards the tension reinforcement and then propagates along the reinforcements (Fig-b) resulting in the failure of the beam by anchorage failure.

CASE III : $2.8 < a_v / d < 6$: Diagonal tension failure.

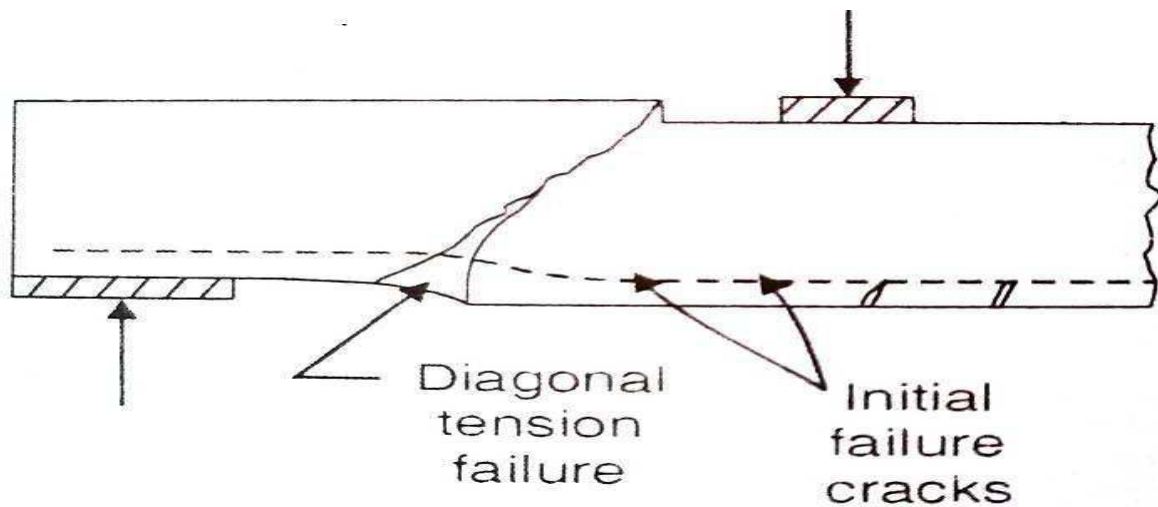

Fig- 5.4.4 CASE III : $2.8 < a_v / d < 6$

Diagonal tension failure occurs when the shear span to the effective depth ratio is in the range of 2.8 to 6 . Normal beams have a_v / d ratio in excess of 2.8. Such beams may fail either in shear or in flexure.

CASE - IV : $a_v / d > 6$: Flexure failure

Flexural failure is encountered when a_v / d ratio > 6 . Two cases may be encountered; (i) under reinforced beam and (ii) over reinforced beam. In the case of under reinforced beam, tension reinforcement is less than the limiting one, due to which failure is initiated by yielding of tension reinforcement, leading to the ultimate failure due to crushing of concrete in compression zone. Such a ductile failure is known as flexural tension failure, which is quite slow giving enough warning. In the over reinforced sections failure occurs due to crushing of concrete in compression zone before yielding of tension reinforcement. Such a failure, known as flexural compression failure is quite sudden.

FACTORS AFFECTING THE SHEAR RESISTANCE OF A R C MEMBER.

The shear resistance of rectangular beams, without shear reinforcements depends on the following factors.

1. Grade of concrete : Higher grade of concrete has higher characteristic strength which in turn results in (i) higher tensile strength (ii) greater dowel shear resistance (iii) greater aggregate interlock capacity, and (iv) greater concrete strength in compression zone. Hence shear resistance increases with the increase in the grade of concrete.

2. Percentage and grade of longitudinal tensile reinforcement : The increase in percentage (p_t) of longitudinal tensile reinforcement results in the increase in dowel shear (V_d). Due to this reason, the design Codes make the shear strength (τ_c) of concrete a function of p_t and grade of concrete (see Table 5.1). However, higher grade of steel results in lesser shear resistance of R.C. beam because the percentage of steel (p_t) corresponding to a higher grade steel is less than that required for a low grade steel, say mild steel.

3. Ratio of shear span to effective depth (i.e. a_v/d ratio) : As discussed in the previous article, for a_v/d ratio between 6 and 2.8, the shear capacity, being governed by inclined crack resistance, decrease with decrease in a_v/d ratio (curve *b* of Fig.5.4.1). However, for a value of a_v/d less than 2.8, the shear capacity, being dependent on *shear-compression* or *shear-bond capacity*, increases rapidly. The minimum shear capacity is at a_v/d ratio around 2.8.

4. Compressive force : Presence of axial compressive force result in increase of shear capacity. The effect of axial compression on the design shear strength has been taken into account by I.S. Code by increasing the design shear strength by a modification factor δ .

5. Compressive reinforcement : The shear resistance is found to increase with the increase in the percentage of compressive steel (p_c).

6. Axial tensile force : Axial tensile force reduces marginally the shear resistance of concrete as per the equation $\delta = 1 - \frac{P_w}{3.45A_g}$.

7. Shear reinforcement: The shear resistance of a R C Beam increases with the increase in shear reinforcement ratio. This is due to two reasons (i) concrete gets conformed between stirrup spacing and (ii) the shear/web reinforcement itself provides shear resistance.

5.6 . DESIGN SHEAR STRENGTH OF CONCRETE WITHOUT SHEAR REINFORCEMENT (IS 456: 2000)

The magnitude of design shear strength (r_c) depends basically on the grade of concrete (f_{ck}) and the percentage of tension steel(P_t). As per IS 456 : 2000 the design shear strength of concrete in beams without shear reinforcement shall be given in table 5.1.

TABLE 5.1 DESIGN SHEAR STRENGTH (τ_c) OF CONCRETE. (N/mm²)

$100 \frac{A_{st}}{bd}$	Grade of concrete					
	M 15	M 20	M 25	M 30	M 35	M 40 and above
≤ 0.15	0.28	0.28	0.29	0.29	0.29	0.30
0.25	0.35	0.36	0.36	0.37	0.37	0.38
0.50	0.46	0.48	0.49	0.50	0.50	0.51
0.75	0.54	0.56	0.57	0.59	0.59	0.60
1.00	0.60	0.62	0.64	0.66	0.67	0.68
1.25	0.64	0.67	0.70	0.71	0.73	0.74
1.50	0.68	0.72	0.74	0.76	0.78	0.79
1.75	0.71	0.75	0.78	0.80	0.82	0.84
2.00	0.71	0.79	0.82	0.84	0.86	0.88
2.25	0.71	0.81	0.85	0.88	0.90	0.92
2.50	0.71	0.82	0.88	0.91	0.93	0.95
2.75	0.71	0.82	0.90	0.94	0.96	0.98
3.0 and above	0.71	0.82	0.92	0.96	0.99	1.01

Analytical expression for design shear strength :

The Values of τ_c given in the above table by the code are based on the following semi empirical expression (SP 24, 1983).

$$\tau_c = \frac{0.85 \sqrt{0.8 f_{ck}} (\sqrt{1 + 5 \beta} - 1)}{6 \beta} \quad \dots\dots 5.6.1$$

where $\beta = \frac{0.8 f_{ck}}{6.89 p_t}$, but not less than 1

$$p_t = \frac{100 A_{st}}{bd} \text{ (percentage steel in rib width only)}$$

0.8 f_{ck} = cylinder strength in terms of cube strength

0.85 = reduction factor similar to $1/\gamma_m$

The formula in BS 8110 for design shear strength of concrete is slightly different, and is given by the expression

$$\tau_c = 0.79 (p_t)^{1/3} \left(\frac{400}{d} \right)^{1/4} \left(\frac{1}{\gamma_m} \right) \left(\frac{f_{ck}}{25} \right)^{1/3} \quad \dots 5.6.2$$

where $\left(\frac{400}{d} \right)$ = the correction factor for depth and should not be less than 1
 $\left(\frac{f_{ck}}{25} \right)$ = the correction factor for the strength of concrete and should not be greater than 40

$$\gamma_m = 1.25$$

p_t = percentage steel, the value of which should not exceed 3

Design shear strength for solid slabs

For solid slabs, the design shear strength for concrete shall be $\tau_c \cdot k$, where k has the values given in Table 5.2

TABLE 5.2 VALUES OF k (IS 456 : 2000)

Overall depth of slab (mm)	300 or more	275	250	225	200	175	150 or less
k	1.00	1.05	1.10	1.15	1.20	1.25	1.30

Note : The above provision shall not apply to flat slabs.

Shear strength of members under axial compression (IS 456 : 2000)

For members subjected to axial compression P_{uc} , the design shear strength of concrete, given in Table 7.1, shall be multiplied by the following factor :

$$\delta = 1 + \frac{3 P_{uc}}{A_g \cdot f_{ck}}, \text{ but not exceeding } 1.5 \quad \dots 5.6.3$$

where P_{uc} = factored axial compressive force in Newtons

A_g = gross area of concrete section in mm^2 , and

f_{ck} = characteristic compressive strength of concrete, in N/mm^2

Shear strength of members under axial tension (ACI Code, 1989) :

Though it is evident that there is some reduction in design shear strength of a member under axial tension, IS Code (IS 456 : 2000) does not explicitly mention this case. However, the following simplified expression for δ , based on ACI Code (1989) may be used :

$$\delta = 1 - \frac{P_{ut}}{3.45 A_g} \quad \dots 5.6.4$$

where P_{ut} = factored axial tensile force in Newtons.

Maximum shear stress in concrete with shear reinforcement (IS 456 : 2000)

(a) Maximum shear stress in beams :

Under no circumstances, even with shear reinforcement, shall the nominal shear stress (τ_v) in beams exceed $\tau_{c, max}$ given in Table 5.3

TABLE 5.3. MAXIMUM SHEAR STRESS r_c , max (N/mm²)

Grade of concrete	M15	M20	M25	M30	M35	M40 & above
r_c , max (N/mm ²)	2.5	2.8	3.1	3.5	3.7	4.0

(b) Maximum shear stress in solid slabs

For solid slabs the nominal shear stress shall not exceed half the appropriate values given in table 5.3.

WEB REINFORCEMENT FOR DIAGONAL TENSION:

As stated earlier, proper reinforcement must be provided to resist the diagonal tension. The shear resisted by shear reinforcement can be worked out by considering the equilibrium of forces across a potential diagonal crack, which is assumed to be inclined at an angle of 45° with axis of the beam. Fig. 7.11 shows a diagonal crack *AB*. Let the web reinforcement be inclined at angle α with the axis of the beam, and be spaced at distance s_v apart. Let the diagonal crack *AB* intersect n number of *web reinforcing bars*.

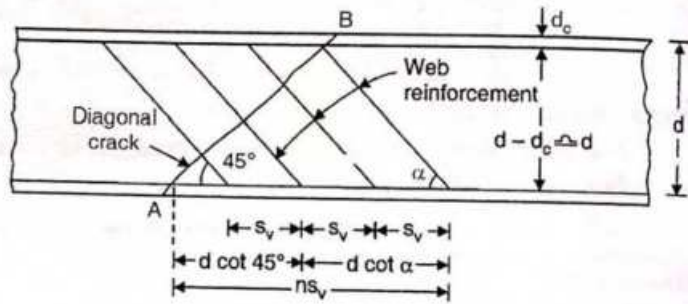

FIG. 5.7.1 SHEAR RESISTED BY WEB STEEL

Let V_{us} = Ultimate shear carried by shear (or web) reinforcement
 f_{yd} = design yield stress in web steel = $0.87 f_y$
 n = number of bars/links crossing the crack
 α = inclination of web steel
 A_{sv} = total cross-section area of each set of bar or link.

The web reinforcement is anchored to the main tensile steel at the bottom, and to the holding bars (at a cover d_c) at the top. Hence the vertical component of length of inclined bar = $(d - d_c)$. Since d_c is normally quite small in comparison to d , we can take $(d - d_c) \approx d$, as marked in Fig. 5.7.1 Now, for equilibrium

Shear carried by shear reinforcement = Sum of vertical components of tensile forces developed in shear reinforcement

$$\therefore V_{us} = n A_{sv} f_{yd} \sin \alpha \quad \dots 5.7.1 (a)$$

In order to get the value of n , we have from geometry,

$$n s_v = d \cot 45^\circ + d \cot \alpha \quad \text{or} \quad n = \frac{d \cot 45^\circ + d \cot \alpha}{s_v} = \frac{d (1 + \cot \alpha)}{s_v} \quad \dots 5.7.1 (b)$$

Substituting the value of n and $f_{yd} (= 0.87 f_y)$ in Eq. 7.13 (a) we get

$$V_{us} = \frac{d (1 + \cot \alpha)}{s_v} \cdot A_{sv} (0.87 f_y) \sin \alpha = \frac{0.87 f_y A_{sv} d}{s_v} (\sin \alpha + \cos \alpha) \quad \dots 5.7.2$$

Rearranging the above, we get

$$s_v = \frac{0.87 f_y A_{sv} d}{V_{us}} (\sin \alpha + \cos \alpha) \quad \dots 5.7.2 (a)$$

The above equation gives the spacing of the bars inclined at α with horizontal.

Here A_{sv} = Area of C/S of bars X No of legs = A_ϕ X No of legs.

Special Cases :

(i) **Bars inclined at 45° .** (i.e. $\alpha = 45^\circ$)

$$\text{If } \alpha = 45^\circ, \quad V_{us} = \frac{0.87 f_y A_{sv} d}{s_v} (\sqrt{2}) \quad \dots 5.7.3$$

$$\dots 5.7.3 (a)$$

or

$$s_v = \frac{0.87 f_y A_{sv} d \sqrt{2}}{V_{us}}$$

(ii) **Bars inclined at 90°** (i.e. vertical stirrups)

$$V_{us} = \frac{0.87 f_y A_{sv} d}{s_v} \quad \dots 5.7.4$$

$$\dots 5.7.4 (a)$$

or

$$s_v = \frac{0.87 f_y A_{sv} d}{V_{us}}$$

(iii) **Single bar or single group of bars**

For a single bar, or single group of bars, all bent up at the same cross-section, we get from Eq. 5.7.1 (a) taking $n = 1$

$$V_{us} = 0.87 f_y \cdot A_{sv} \sin \alpha \quad \dots 5.7.5$$

TYPES OF SHEAR REINFORCEMENT.

Shear reinforcement is necessary if the nominal shear stress (r_v) exceeds the design shear stress r_c . In general shear reinforcement is provided in any one of the following three forms.

- Vertical stirrups
- Bent up bars along with the stirrups.
- Inclined stirrups.

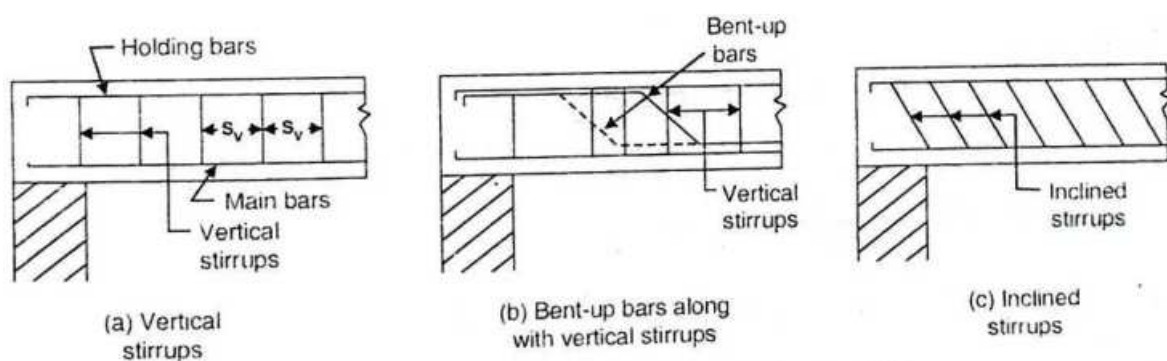

FIG. 5.8 TYPES OF SHEAR REINFORCEMENT

Where bent-up bars are provided, their contribution towards shear resistance shall not be more than half that of total shear reinforcement.

The total external shear V_u is jointly resisted by concrete as well as shear reinforcement and is represented by the expression

$$V_u = V_{uc} + V_{us}$$

Where V_{uc} = Shear strength of concrete and

V_{us} = Shear reinforcement.

VERTICAL STIRRUPS:

Shear reinforcement in the form of vertical stirrups consists of 5 mm to 15 mm dia steel bars bend round the tensile reinforcement where it is anchored to 6 to 12 mm dia. Anchor bars or holding bars. Depending upon the magnitude of the shear stress to be resisted , a stirrup may be one legged, two legged, four legged or multi legged, as shown in Figure.

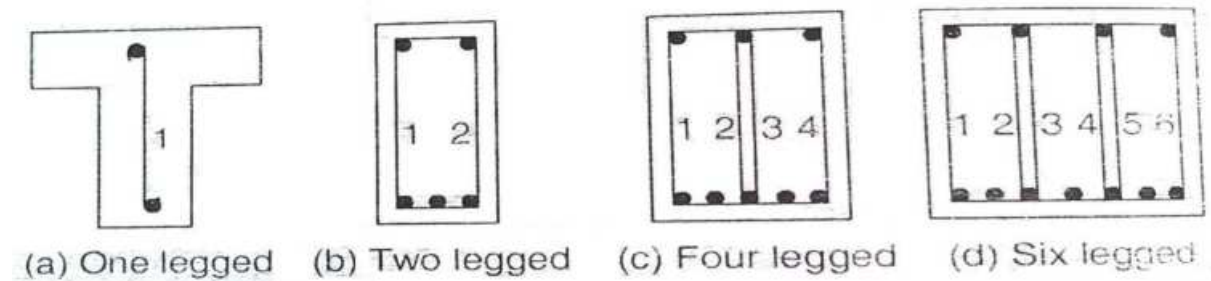

FIG-5.9. FORMS OF VERTICAL STIRRUPS

The strength of shear reinforcement in the form of vertical stirrups is given by

$$V_{us} = \frac{0.87 f_v A_{sv} d}{s_v} \dots\dots\dots 5.9.1$$

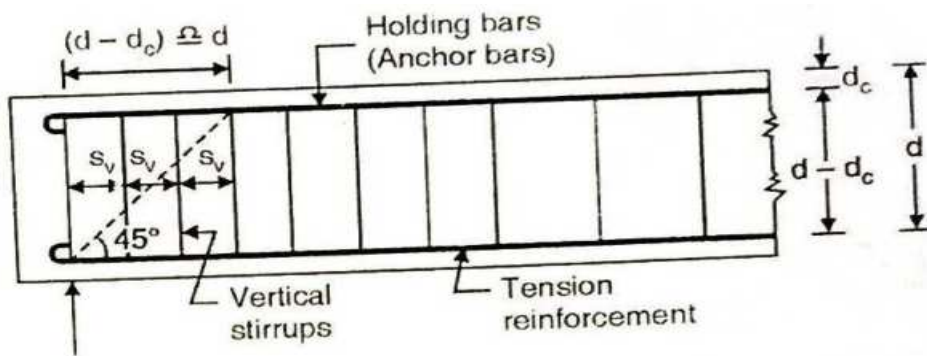

FIG. 5.9.1 SPACING OF VERTICAL STIRRUPS

Here $A_{sv} = m A_\phi$, where m = no of legs in the stirrups and A_ϕ = Area of c/s of the bar stirrups.

Let us assume that in absence of shear reinforcement, the beam fails in diagonal tension, the inclination of the tension crack being at 45° to the axis of the beam and extended up to a horizontal distance equal to $(d - d_c) = d$

Hence No of stirrups resisting shear force = d/S_v , Or,

$$V_{us} = 0.87 f_y \cdot A_{sv} \times \frac{d}{s_v}$$

$$s_v = \frac{0.87 f_y \cdot A_{sv} \cdot d}{V_{us}} = \frac{0.87 f_y \cdot A_{sv} \cdot d}{V_u - V_{uc}} \quad \dots \quad 5.9.4$$

Spacing diagram for vertical stirrups. The spacing of the stirrups at any section along the length of the beam can be determined from Eq. 5.9.1 since the net shear V_{us} at that section can be easily determined. This will give variable spacings all along the length of the beam. These variable spacings can be averaged out by the construction of *spacing diagram*.

Procedure. (1) Determine net shear force at various sections distant x_1, x_2, x_3 etc. from the support and calculate the spacings at these sections.

(2) Plot the spacing diagram with the calculated spacing as ordinate (Fig. 5.9.2)

(3) Calculate the spacing of the first stirrup, on the basis of net S.F. at the support. Set the first stirrup at half the distance of this spacing, from the support.

(4) Where this ordinate at (1) intersects the spacing diagram, set a line at 45° , meeting the span line in (2). This will give the position of the second stirrup. Repeat this procedure to get the position of other stirrups.

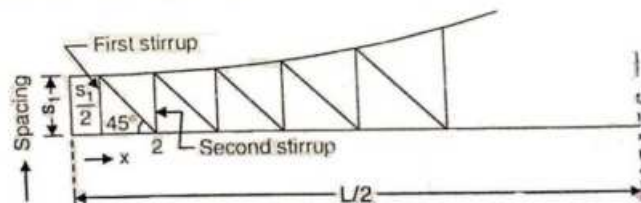

FIG. 5.9.2 SPACING DIAGRAM.

MINIMUM SHEAR REINFORCEMENT (IS 456 : 2000)

The shear reinforcement in the form of stirrups remain unstressed till the diagonal crack occurs at the critical location. However, the instant a diagonal crack occurs. The web reinforcement receives sudden increase in stress. If web reinforcement is not provided. Shear failure may occur without giving any warning. The code therefore, specifies that all the beams should be provided with atleast some minimum reinforcement called nominal shear reinforcement even if nominal shear stress is less than the design shear stress of concrete.

Reasons for providing minimum shear reinforcement:

1. It prevents *sudden* shear failure with the formation of diagonal tension crack, and imparts *ductility* to provide sufficient warning of impending failure. Thus *brittle shear failure* is prevented.
2. It guards against any sudden failure of a beam if concrete cover bursts and bond to tension steel is lost.
3. It holds the main reinforcements in place while pouring the concrete. Thus minimum requirement of cover and clear distance between longitudinal bars are maintained.
4. It acts as necessary ties for the compression steel (if any) and makes it effective.
5. It prevents pressing down of the longitudinal reinforcement, thereby maintaining the *dowel capacity*.
6. It confines the concrete, thereby increasing its strength and rotation capacity.
7. It prevents failure that can be caused by tension due to shrinkage and thermal stresses and internal cracking in the beam.

As per IS 456 : 2000, minimum shear reinforcement in the form of stirrups shall be provided such that

$$\frac{A_{sv}}{b s_v} \geq \frac{0.4}{0.87 f_y} \quad \dots 5.10.1$$

where

A_{sv} = total cross-sectional area of stirrup legs effective in shear.

s_v = stirrup spacing along the length of the member

b = breadth of beam or breadth of the web of flanged beam.

f_y = characteristic strength of stirrup reinforcement in N/mm^2 , which shall not be taken greater than $415 N/mm^2$.

Hence spacing based on minimum shear reinforcement is given by

$$s_v \leq \frac{0.87 f_y \cdot A_{sv}}{0.4 b} \leq \frac{2.175 f_y A_{sv}}{b} \quad \dots 5.10.2$$

However, where the maximum shear stress calculated is less than half the permissible value, and in members of minor structural importance such as lintels, this provision need not be complied with.

Shear resistance of minimum shear reinforcement

The shear resistance of minimum reinforcement envisaged in Eq. 5.10.1 is found by substituting the value of $\frac{0.87 f_y \cdot A_{sv}}{s_v} = 0.4 b$ (

$$\text{Thus, } V_{us, min} = \left(0.87 \frac{f_y A_{sv}}{s_v} \right) d = (0.4 b) d = 0.4 b d \quad \dots 5.10.3$$

Thus, shear carried by concrete and that carried by minimum stirrups is given by

$$V_{u, min} = \tau_c \cdot b d + 0.4 b d \quad \dots 5.10.4$$

MAXIMUM SPACING OF SHEAR REINFORCEMENT:-

The maximum spacing of shear reinforcement measured along the axis of the member shall not exceed $0.75d$ for vertical stirrups and d for inclined stirrups at 45° , where d is the effective depth of the section under consideration. In no case shall the spacing exceed 300 mm.

Example-5.1.

A reinforced concrete beam 250 mm wide and 400 mm effective depth is subjected to ultimate design shear force of 150 kN at the critical section near supports. The tensile reinforcement at the section near supports is 0.5 percent. Design the shear stirrups near the supports also design the minimum shear reinforcement at the mid span. Assume M20 concrete and F_e 250 mild steel.

Solution : Given : $b = 250$ mm ; $d = 400$ mm; $A_{st}/bd = 0.5\% = 0.005$

$$\tau_v = \frac{V_u}{bd} = \frac{150 \times 10^3}{250 \times 400} = 1.5 \text{ N/mm}^2$$

From Table 5.1 $\tau_c = 0.48 \text{ N/mm}^2$ for M 20 concrete and $100 A_{st}/bd = 0.5$

Also, from Table 5.3 $\tau_{c, max} = 2.8 \text{ N/mm}^2$ for M 20 concrete.

Thus, τ_v is less than $\tau_{c, max}$, but greater than τ_c . Hence shear reinforcement is necessary.

$$V_{uc} = \tau_c bd = 0.48 \times 250 \times 400 = 48000 \text{ N}$$

Hence $V_{us} = V_u - V_{uc} = 150000 - 48000 = 102000 \text{ N}$

The shear resistance of nominal stirrups is given by

$$V_{us, min} = 0.4 bd = 0.4 \times 250 \times 400 = 40000 \text{ N} < V_{us}$$

Hence nominal stirrups are *not* sufficient at the section near supports.

We Know that
$$s_v = \frac{0.87 f_y A_{sv}}{V_{us}} \cdot d$$

Using two legged stirrups of 10 mm dia. bars, $A_{sv} = 2 \frac{\pi}{4} (10)^2 = 157.08 \text{ mm}^2$

$$\therefore s_v = \frac{0.87 \times 250 \times 157.08}{102000} \times 400 \approx 134 \text{ mm}$$

Again we know
$$s_v = \frac{0.87 f_y A_{sv}}{(\tau_v - \tau_c) b} = \frac{0.87 \times 250 \times 157.08}{(1.5 - 0.48) 250} \approx 134 \text{ mm}$$

Maximum spacing = $0.75 d$ or 300 mm, which ever is less.

Hence provide 10 mm dia. two legged stirrups @ 130 mm c/c at the section near supports.

At mid-span, the spacing of minimum shear reinforcement for 10 mm ϕ - 2 lgd stirrups is given by Eqn 5.10.2

$$s_v = 0.87 \frac{f_y A_{sv}}{0.4 b} = \frac{0.87 \times 250 \times 157.08}{0.4 \times 250} = 341.6 \text{ mm}$$

However, maximum spacing is limited to $0.75 d$ or 300 mm which ever is less.

Hence $s_v = 300$ mm.

Hence provide 10 mm dia. two legged stirrups @ 300 mm c/c at the mid-span.

Example- 5.2 -

A simply supported beam, 300 mm wide and 500 mm effective depth carries a uniformly distributed load of 50 KN/m, including its own weight over an effective span of 6 m. Design the shear reinforcement in the form of vertical stirrups. Assume that the beam contains 0.75% of reinforcement throughout the length. The concrete is of M 20 grade and steel for stirrups is of Fe 250 grade. Take width of support as 400 mm.

Solution:- $W_u = 1.5 \times 50 = 75 \text{ KN/m}$.

$$V_{u \max} = W_u L/2 = (75 \times 6)/2 = 225 \text{ KN}$$

The critical section lies at a distance of $d = 500 \text{ mm}$ from the face of support or at a distance of $500 + 400/2 = 700 \text{ mm}$ from the centre of the support.

$$V_{uD} = 225 - 75 \times 0.7 = 172.5 \text{ kN.}$$

$$\text{And } r_v = (172.5 \times 10^3) / (300 \times 500) = 1.15 \text{ N/mm}^2.$$

From Table-5.1 for $100 A_s/bd = 0.75\%$, we get $r_c = 0.56 \text{ N/mm}^2$ for M20 Concrete.

$$V_{uc} + 0.56 \times 300 \times 500 = 84000 \text{ N} = 84 \text{ KN.}$$

Also, $\tau_{v, \max} = 2.8 \text{ N/mm}^2$ for M 20 concrete. Since $\tau_v < \tau_{v, \max}$ it is OK.

However, $\tau_v > \tau_c$; hence shear reinforcement is necessary.

$$V_{us} = V_{uD} - V_{uc} = 172500 - 84000 = 88500 \text{ N}$$

Using 10 mm ϕ 2-lgd vertical stirrups, $A_{sv} = 2 \frac{\pi}{4} (10)^2 = 157.1 \text{ mm}^2$

$$\therefore \text{Spacing } s_v = \frac{0.87 f_y \cdot A_{sv} \cdot d}{V_{us}} = \frac{0.87 \times 250 \times 157.1 \times 500}{88500} = 193 \text{ mm} \hat{=} 190 \text{ mm (say)}$$

Spacing corresponding to minimum shear reinforcements is

$$s_v = \frac{0.87 f_y A_{sv}}{0.4 b} = \frac{0.87 \times 250 \times 157.1}{0.4 \times 300} = 284.7 \text{ mm} \hat{=} 280 \text{ mm (say)}$$

However in no case should the spacing exceed $0.75 d = 0.75 \times 500 = 375 \text{ mm}$, or 300 mm whichever is less. Hence the spacing is to vary from 190 mm at the end section @ 280 mm at a section distant $x \text{ m}$ (say) from the mid-span. Let us locate this section where the S.F. is V_{ux} .

$$\therefore V_{ux} = \frac{V_{u, \max}}{3} x = \frac{225000}{3} x = 75000 x$$

$$\therefore V_{us} = V_{ux} - V_{uc} = 75000 x - 84000$$

$$s_v = 280 = \frac{0.87 \times 250 \times 157.1 \times 500}{75000 x - 84000}$$

from which, we get $x = 1.93 \text{ m}$ from mid-span or 1.07 m from supports. Hence provide 8 mm ϕ 2 lgd stirrups at a spacing of 190 mm c/c from supports to a section distant 1.07 m from the centre of either supports. For the remaining length, provide the stirrups @ 280 mm c/c.

CHAPTER-6

BOND, ANCHORAGE, DEVELOPMENT LENGTHS, AND SPLICING

5. BOND:

One of the most important assumption in the behavior of reinforced concrete structure is that there is proper 'bond' between concrete and reinforcing bars. The force which prevents the slippage between the two constituent materials is known as bond. In fact, bond is responsible for providing 'strain compatibility' and composite action of concrete and steel. It is through the action of bond resistance that the axial stress (tensile or compressive) in a reinforcing bar can undergo variation from point to point along its length. This is required to accommodate the variation in bending moment along the length of the flexural member.

When steel bars are embedded in concrete, the concrete, after setting, adheres to the surface of the bar and thus resists any force that tends to pull or push this rod. The intensity of this adhesive force bond stress. The bond stresses are the longitudinal shearing stress acting on the surface between the steel and concrete, along its length. Hence bond stress is also known as interfacial shear. Hence bond stress is the shear stress acting parallel to the reinforcing bar on the interface between the bar and the concrete.

TYPES OF BOND:-

Bond stress along the length of a reinforcing bar may be induced under two loading situations, and accordingly bond stresses are two types :

1. Flexural bond or Local bond
2. Anchorage bond or development bond

Flexural bond (τ_{bf}) is one which arises from the change in tensile force carried by the bar, along its length, due to change in bending moment along the length of the member. Evidently, flexural bond is critical at points where the shear ($V=dM/dx$) is significant. Since this occurs at a particular section, flexural bond stress is known as local bond stress [Fig- 5.1(b)].

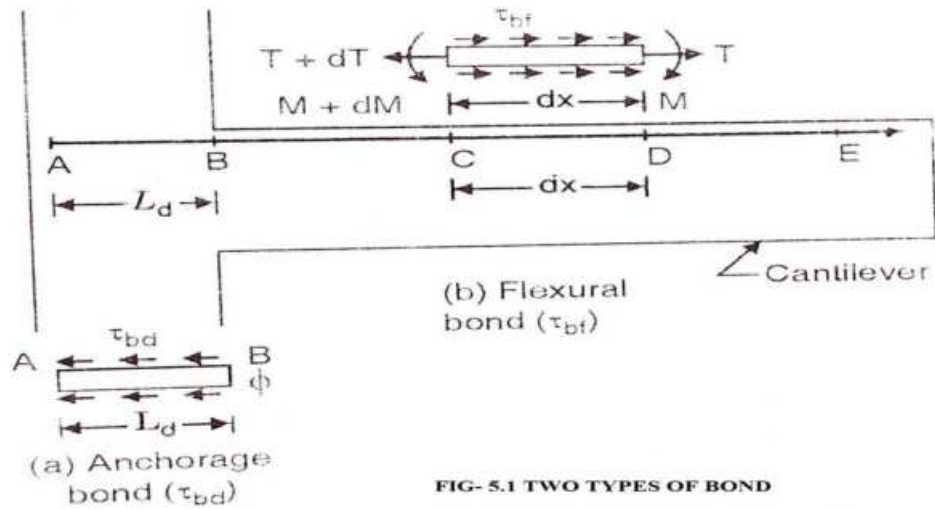

Anchorage bond (τ_{bd}) is that which arises over the length of anchorage provided for a bar. It also arises near the end or cutoff point of reinforcing bar. The anchorage bond resists the ‘pulling out’ of the bar if it is in tension or ‘pushing in’ of the bar if it is in compression. Fig.[8.1 (a)] shows the situation of anchorage bond over a length AB(= L_d). Since bond stresses are developed over specified length L_d , anchorage bond stress is also known as developed over a specified length L_d , anchorage bond stress is also known as development bond stress.

Anchoring of reinforcing bars is necessary when the development length of the reinforcement is larger than the structure. Anchorage is used so that the steel's intended tension load can be reached and pop-outs will not occur. Anchorage shapes can take the form of 180 or 90 degree hooks.

5.2. ANCHORAGE BOND STRESS:

Fig- 5.2 shows a steel bar embedded in concrete And subjected to a tensile force T . Due to this force There will be a tendency of bar to slip out and this tendency is resisted by the bond stress developed over the perimeter of the bar, along its length of embedment .

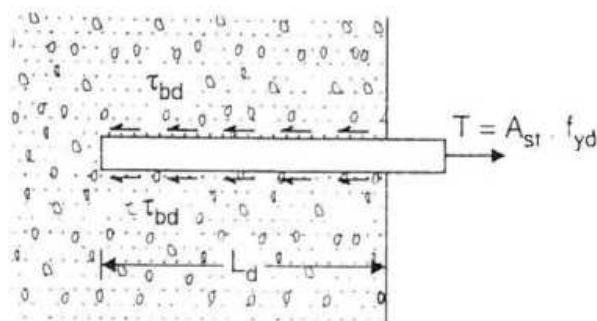

FIG- 5.2

Let us assume that average uniform bond stress is developed along the length. The required length necessary to develop full resisting force is called **Anchorage length** in case of axial tension or compression and **development length** in case of flexural tension and is denoted by L_d .

DESIGN BOND STRESS:-

The design bond stress in limit state method for plain bars in tension shall be as given below (Table 6.1)

Table- 6.1

Grade of concrete	M 20	M 25	M 30	M 35	M 40 and above
Design bond stress τ_{bd} (N/mm ²)	1.2	1.4	1.5	1.7	1.9

Design bond stresses for deformed bars in tension : For deformed bars conforming to IS 1786. These values shall be increased by 60%.

Design bond stress for bars in compression : For bars in compression, the values of bond stress for in tension shall be increased by 25%.

DEVELOPMENT LENGTH OF BARS (IS 456 : 2000)

The development length is defined as the length of the bar required on either side of the section under consideration, to develop the required stress in steel at that section through bond. The development length L_d given by

$$L_d = \phi \sigma_s / 4 \tau_{bd} = k_d \phi \dots\dots\dots 5.4.1$$

- Where ϕ = nominal diameter of the bar
- σ_s = stress in bar at the section considered at design load
- k_d = development length factor = $\sigma_s / 4 \tau_{bd}$

Note : The development length includes the anchorage values of hooks in tension reinforcement

Taking $\sigma_s = 0.87 f_y$ at the collapse stage, $k_d = 0.87 f_y / 4 \tau_{bd} \dots\dots\dots 5.4.2$

For bars in compression, the value of τ_{bd} given in table 1.1 are to be increased by 25%. Hence developed length (L_{dc}) for bars in copressio is given by

$$L_{ds} = \phi \sigma_{sc} / 5 \tau_{bd} \dots\dots\dots 5.4.3$$

Hence the values of k_d for bars in compression will be $=0.87 f_y/5 \tau_{bd}$

Table 6.2 gives the values of development length factor for various grades of concrete and the various grades of steel, both in tension as well as compression. The values have been rounded-off to the higher side.

TABLE 6.2- VALUES OF DEVELOPMENT LENGTH FACTOR

Grade of concrete	M 20			M 25		
	Fe 250	Fe 415	Fe 500	Fe 250	Fe 415	Fe 500
Bars in tension	46	47	57	39	41	49
Bars in comp.	37	38	46	31	33	39

Grade of concrete	M30			M35			M40		
	Fe 250	Fe 415	Fe 500	Fe 250	Fe 415	Fe 500	Fe 250	Fe 415	Fe 500
Bars in tension	37	38	46	32	34	40	29	30	36
Bars in comp.	29	31	37	26	27	32	23	24	29

Note : When the actual reinforcement provided is more than that theoretically required, so that the actual stress (σ_s) in steel is less than the full design stress ($0.87 f_y$), the development length required may be reduced by the following relation :

$$\text{Reduced development length } L_{dr} = L_d (A_{st \text{ required}} \div A_{st \text{ provided}})$$

This principle is used in the design of footing and other short bending members where bond is critical. By providing more steel, the bond requirements are satisfied.

Bars bundled in contact : The development length of each bar bundled bars shall be that for the individual by 10% for two bars in contact, 20% for three bars in contact and 33% for four bars in contact.

STANDARD HOOKS & BENDS FOR END ANCHORAGE ANCHORAGE LENGTH

The development length required at the end of a bar is known as *anchorage length*. However, in the case of development length, the force in the bar is developed by transfer of force from concrete to steel, while in the case of anchorage length, there is dissipation of force from steel to concrete.

Quite often, space available at the end of beam is limited to accommodate the full development length L_d . In that case, hooks or bends are provided. The anchorage value (L_a) of hooks or bend is accounted as contribution to the development length L_d .

Fig. 5.5 (ai) shows a semi-circular hook, fully dimensioned, with respect to a factor K . The value of K is taken as 2 in the case of mild steel conforming to IS : 432-1966, (specifications for Mild-Steel and Medium Tensile Steel bars and Hard-Drawn steel wires for concrete reinforcement) or IS : 1139-1959, (specifications for 'Hot rolled mild steel and medium tensile steel deformed bars for concrete reinforcement'). The hook with $K = 2$ is shown in Fig. 5.5 (a(ii)) with equivalent horizontal length of the hook. For the case of Medium Tensile Steel conforming to IS : 432-1966 or IS : 1139-1959, K is taken as 3. In the case of cold worked steel conforming to IS : 1986-1961, (specifications for cold twisted steel bars for concrete reinforcement), K is taken as 4. In the case of bars above 25 mm, however, it is desirable to increase the value of K to 3, 4 and 6 respectively.

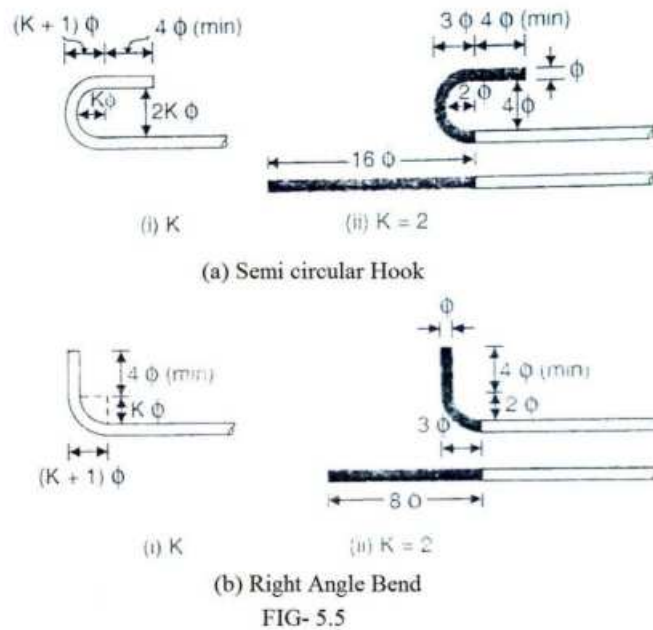

FIG- 5.5

Fig- 5.5 shows a right angled bend, with dimensions in terms of K , the value of which may be taken as 2 for ordinary mild steel for diameters below 25 mm and 3 for diameters above 25 mm.

In the case of deformed bars, the value of bond stress for various grades of concrete is greater by 60% than the plane bars. Hence deformed bars may be used without hooks, provided anchorage requirements are adequately met with.

CODE REQUIREMENTS FOR ANCHORING REINFORCING BARS (IS 456 : 2000)

- (i) **Anchoring Bars in Tension :-** Deformed bars may be used without end anchorages provided development length required is satisfied. Hooks should normally be provided for plain bars in tension. The anchorage value of bend shall be taken as 4 times the diameter of the bar for each 45° bend subject to a maximum of 16 times the diameter of the bar. The anchorage value of a standard U-type hook shall be equal to 16 times the diameter of the bar.
- (ii) **Anchoring Bars in Compression :-** The anchorage length of straight bar in compression shall be equal to the development length of bars in compression. The projected length of

hooks, bends and straight lengths beyond bends if provided for a bar in compression, shall be considered for development length.

(iii) Anchoring Shear Reinforcement :-

Inclined bars :- The developments length shall be as for bars in tension ; this length shall be measured as under : (1) in tension zone from the end of the sloping or inclined portion of the bar and (2) in the compression zone, from mid depth of the beam.

Stirrups :- Notwithstanding any of the provisions of this standard, in case of secondary reinforcement , such as stirrups and traverse ties, complete development lengths and anchorage shall be deemed to have been provided when the bar is bent through an angle of atleast 90° round a bar of atleast its own diameter and is continued beyond the end of the curve for a length of atleast eight diameters, or when the bar is bent through an angle of 135° and is continued beyond the end of curve for a length of atleast six bar diameters or when the bar is bent through an angle of 180° and is continued beyond the end of the curve for a length atleast four bar diameters.

CHECKING DEVELOPMENTS LENGTH OF TENSION BARS :-

As stated earlier, the computed stress (σ_s) in a reinforcing bar, at every section must be developments on both the sides of section. This is done by providing development length L_d to both sides of the section. Such a developments length is usually available at mid-span location where positive (or sagging) B.M. is maximum for simply supported beams. Similarly, such a developments length is usually available at the intermediate support of a continuous beam where negative (or hogging) B.M. is maximum. Hence no special checking may be necessary in such locations. However special checking for developments length is essential at the following locations :

1. At simple supports
2. At cantilever supports
3. In flexural members that have relatively short spans
4. At points of contraflexure
5. At lap splices
6. At points of bar cutoff
7. For stirrups and transverse ties.

**DEVELOPMENTS LENGTH REQUIREMENTS AT SIMPLE SUPPORTS :
DIAMETER OF REINFORCING BARS :-**

The code stipulates that at the simple supports (and at the point of inflection), the positive moment tension reinforcement shall be limited to a diameter such that

$$L_d \leq M_1/V + L_o \dots\dots\dots 5.8.1$$

Where L_d = developments length computed for design stress f_{yd} ($=0.87 f_y$) from Eqⁿ

M_1 = Moments resistance of the section assuming all reinforcement at the section to be stressed to f_{yd} (= $0.87 f_y$)

V = Shear force at the section due to design loads

L_o = sum of anchorage beyond the centre of supports and the equivalent anchorage value of any hook or mechanical anchorage at the simple support (At the point of inflexion, L_o is limited to d or 12ϕ which ever is greater).

The code further recommends that the value of M_1/V in eqⁿ - 5.8.1 may be increased by 30% when the ends of the reinforcement are confined by a compressive reaction. This condition of confinement of reinforcing bars may not be available at all the types of simple supports.

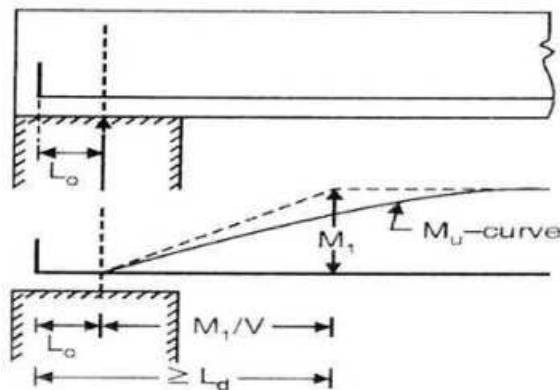

FIG-5.8.1

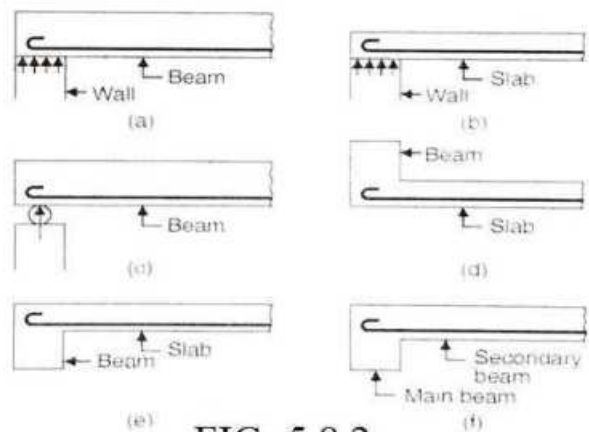

FIG- 5.8.2

Four type of simple supports are shown in fig-5.8.2. In fig- 5.8.2 (a) , the beam is simply supported on a wall which offers a compressive reaction which confines the ends of reinforcement. Hence a factor 1.3 will be applicable. However in fig-5.8.1 (c) and (d) though a simple support is available , the reaction does not confine the ends of the reinforcement, hence the factor 1.3 will not be applicable with M_1/V term. Similarly for the case of a slab connected to a beam Fig- 5.8.2(e) or for the case of secondary beam connected to a main beam [Fig-5.8.2(f)]

Tensile reaction is induced and hence a factor 1.3 will not be available.

Thus at simple supports where the compressive reaction confines the ends of reinforcing bars we have $L_d \leq 1.3 M_1/V + L_o$ 5.8.2

Computation of the Moment of Resistance M_1 of bars available at supports:

In eqn 5.8.1 , M_1 = Moment of Resistance of the section corresponding to the area of steel (A_{st}) continued into the support and stressed to design stress equal to design stress equal to $0.87f_y$.

$$M_1 = 0.87f_y \cdot A_{st} (d - 0.416 X_u) \dots\dots\dots 5.8.3$$

$$\text{Where } X_u = 0.87f_y \cdot A_{st} / 0.36f_{ck} b \dots\dots\dots 5.83(a)$$

Computation of Length (L₀) :

For the computation of L₀ , the support width should be known. Fig- 5.8.3 (a) and (b) show a beam with end support with a standard hook and 90° bend respectively.

Let X be the side cover to the hook (Or bend) and X₀ be the distance of the beginning of the hook (Or Bend) from the center line of the support.

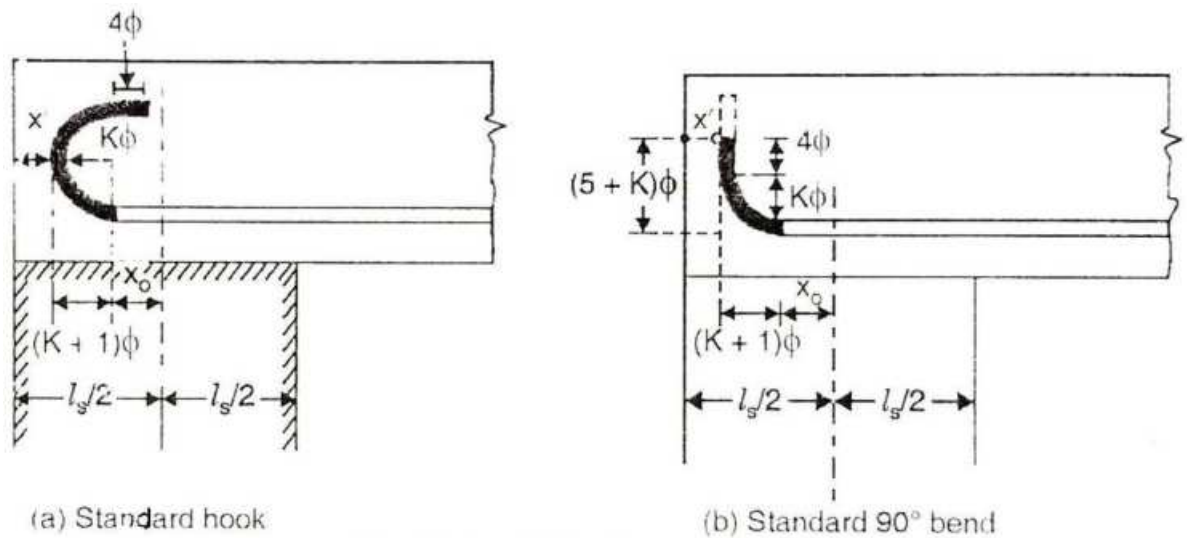

FIG 5.8.3 COMPUTATION OF L_d

(a) **Case-I : Standard Hook at the end [Fig-5.8.3(a)]:-** The dark portion shows the hook which has an anchorage value of 16ϕ (IS 456: 2000) for all types of steel. The distance of the beginning of the hook from its apex of the semi circle is equal to $(K+1)\phi$. For mild steel bars $K=2$ and for HYSD bars, $K=4$, Hence the distance ϕ for mild steel and 5ϕ for HYSD bars. Let l be the width of the support.

$$\begin{aligned} \text{Then} \quad L_0 &= x_0 + 16 \phi \quad \text{where} \quad x_0 = \frac{l_s}{2} - x' - (K + 1) \phi \\ \therefore L_0 &= \left(\frac{l_s}{2} - x' - (K + 1) \phi \right) + 16 \phi = \frac{l_s}{2} - x' + (15 - K) \phi \quad \dots\dots 5.84 \end{aligned}$$

$$\text{Taking } K = 2 \text{ for mild steel bars, } L_0 = \frac{l_s}{2} - x' + 13 \phi \quad \dots\dots 5.84(a)$$

$$\text{Taking } K = 4 \text{ for HYSD bars, } L_0 = \frac{l_s}{2} - x' + 11 \phi \quad \dots\dots 5.84(b)$$

(b) **Case 2 : 90° standard bend** (Fig. 8.7 b) : The dark portion shows the 90° bend which has an anchorage value of 8ϕ (IS 456 : 2000) for all types of steel. Here also, the distance of beginning of the hook from its apex of the semi-circle is equal to $(K + 1) \phi$.

$$\begin{aligned} \text{Then} \quad L_0 &= x_0 + 8 \phi \quad \text{where} \quad x_0 = \frac{l_s}{2} - x' - (K + 1) \phi \\ \therefore L_0 &= \left(\frac{l_s}{2} - x' - (K + 1) \phi \right) + 8 \phi = \frac{l_s}{2} - x' + (7 - K) \phi \quad \dots 5.8.5 \end{aligned}$$

$$\text{Taking } K = 2 \text{ for mild steel bars, } L_0 = \frac{l_s}{2} - x' + 5 \phi \quad \dots 5.8.5(a)$$

$$\text{Taking } K = 4 \text{ for HYSD bars } L_0 = \frac{l_s}{2} - x' + 3 \phi \quad \dots\dots 5.8.5(b)$$

Remedies to get development length : If the check for the satisfaction of Eq. 5.8.1 is not obtained, following remedial measures may be adopted to satisfy the check .

1. Reduce the diameter ϕ of the bar, thereby reducing the value of L_d , keeping the area of steel at the section unchanged. This is the standard procedure envisaged in the Code, i.e. reducing the value of L_d by *limiting* the diameter of the bar to such a value that Eq. 8.6 is satisfied.

2. Increasing the value of L_0 by providing *extra length* of the bend over and above the standard value $(5 + K) \phi$ shown by dotted lines in Fig. 5.8.2 (b).

3. By increasing the number of bars (there by increasing A_{qt}) to be taken into the support. This method is uneconomical.

4. By providing adequate mechanical anchorage.

We shall discuss the first remedial method in the following section.

CONDITIONS FOR CURTAILMENT OF REINFORCEMENT

In most of the cases, the B.M. varies appreciably along the span of the beam. From the point of view of economy, the moment of resistance of the beam should be reduced along the span according to the variation of B.M. This is effectively achieved by reducing the area of reinforcement, i.e. by curtailing the reinforcement provided for maximum B.M. In general, all steel, whether in tension or in compression, should extend d or 12ϕ (whichever is greater) beyond the theoretical point of cut off (TPC).

Conditions for termination of tension reinforcement in flexural members:

Curtailment of Flexural tension reinforcement results in the loss of shear strength in the region of cutoff and hence it is necessary to make provision to guard against such loss. Flexural reinforcement shall not be terminated in a tension zone unless any one of the following condition is satisfied.

(a) The shear at the cutoff point does not exceed two thirds that permitted, including the shear strength of web reinforcement. In other words, the total *shear capacity* shall be atleast 1.5 times the applied shear at the point of curtailment, thus

$$V_u \leq \frac{2}{3} (V_{uc} + V_{us}) \quad \text{or} \quad V_{uc} + V_{us} \geq 1.5 V_u$$

Where V_{uc} = shear capacity of concrete, based on continuing reinforcement only.

V_{us} = shear capacity of shear reinforcement

V_u = applied shear at the point of curtailment.

(b) Stirrup area in excess of that required for shear and torsion is provided along each terminated bar over a distance from cutoff point equal to three fourth the effective depth of the member. Excess area of shear reinforcement is given by :

$$\text{Excess} \quad A_{sv} \geq \frac{0.4 b s_v}{f_y}$$

where

$$s_v \leq \frac{d}{8 \beta_b} \leq \frac{0.87 f_y A_{sv}}{0.4 b}$$

$$\beta_b = \frac{\text{area of bars cutoff at the section}}{\text{total area of bars at the section}}$$

(c) For 36 mm or smaller bars, the continuing bars provide double the area required for flexure at the cutoff point and the shear does not exceed three fourth that permitted.

$$\text{Thus,} \quad M_{ur} \geq 2 M_u$$

and

$$V_{uc} + V_{us} \geq 1.33 V_u$$

where

M_{ur} = moment of resistance of remaining (or continued) bars

M_u = B.M. at cutoff point ; V_u = S.F. at cutoff point

5.9 DEVELOPMENT LENGTH AT POINT OF INFLEXION

Fig. 8.8 shows the conditions at a point of inflexion (P.I.) As already indicated in § 8.11, the Code states that the following condition be satisfied

$$\left(\frac{M_1}{V} + L_0 \right) \geq L_d \quad \dots\dots 5.9.1$$

where L_0 should not be greater than d or 12ϕ whichever is greater, and V is the shear force at the point of inflexion.

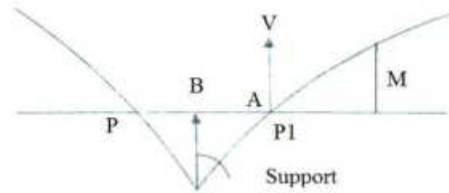

FIG. 5.9 DEVELOPMENT LENGTH AT A POINT OF INFLEXION

5.10 SPLICING:

(a) The purpose of splicing is to transfer effectively the axial force from the terminating bar to the connecting bar with the same line of action at the junction. [Fig-5.10 (a)].

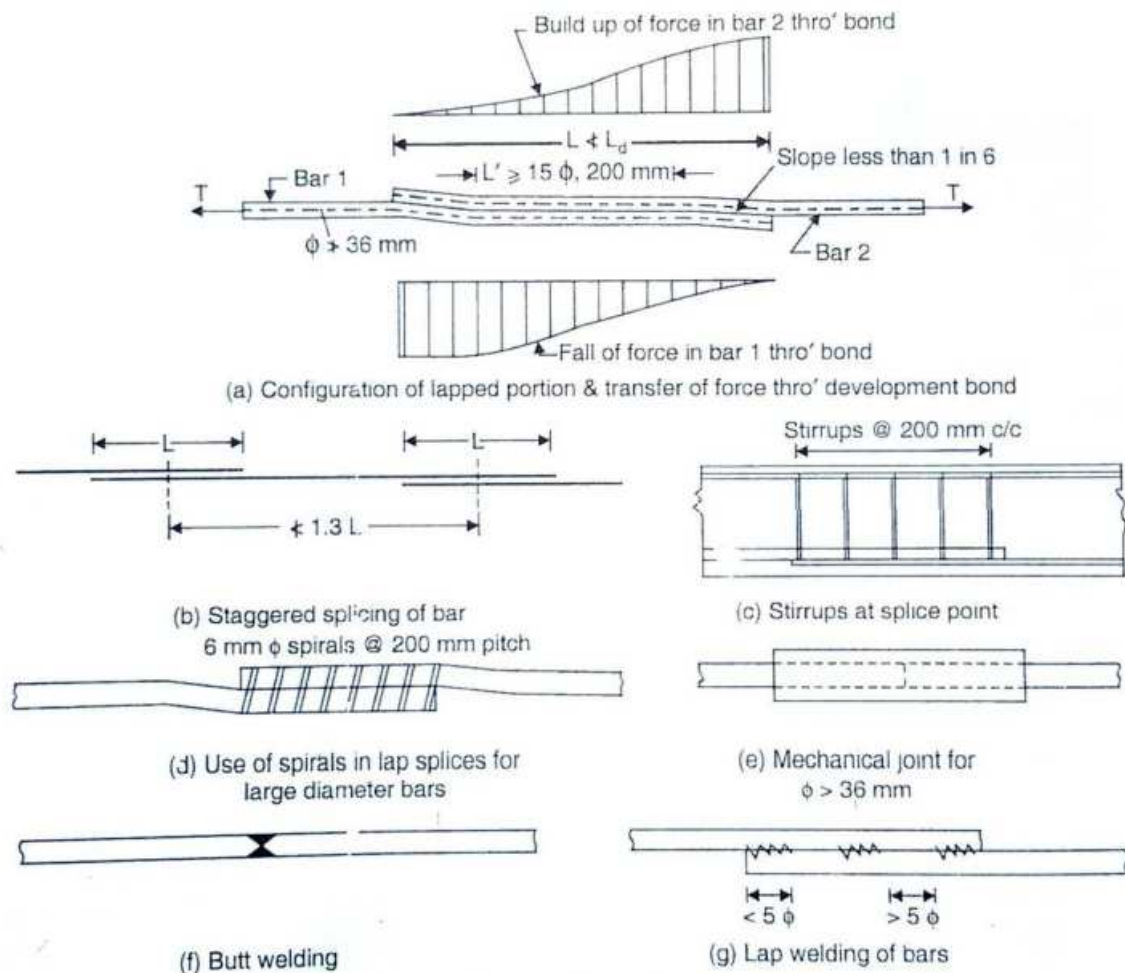

FIG- 5.10 REINFORCEMENT SPLICING

Slicing of a bar is essential in the field due to either the requirements of construction or non availability of bars of desired length. The Figures given are as per the recommendation of the IS 456 : 2000.

(a) Lap splices shall not be used for bars larger than 36 mm. For larger diameters bars may be weld. In case where welding is not practicable , lapping of bars larger than 36mm may be permitted, in which case additional spiral should be provided around the lapped bars [Fig-5.10(d)].

(b) Lap splices shall be considered as staggered if the centre to centre distance of the splices is; not less than 1.3 times the lap length calculated as described in (c).

(c) The lap length including anchorage value of hooks for bars in *flexural tension shall be L_d or 30ϕ* whichever is greater and for *direct tension shall be $2 L_d$ or 30ϕ* whichever is greater. The *straight length (L')* of the lap shall not be less than 15ϕ or 200 mm (Fig. 5.10 [a]) The following provisions shall also apply :

(1) Top of a section as cast and the minimum cover is less than twice the diameter of the lapper bar, the lapped length shall be increased by a factor of 1.4.

(2) Corner of a section and minimum cover to either face is less than twice the diameter of the lapped bar or where the clear distance between adjacent laps is less than 75 mm or 6 times the diameter of lapper bar, whichever is greater, the lap length should be increased by a factor of 1.4.

Where both conditions (1) and (2) apply , the lap length should be increased by a factor of 2.0.

Note : Splices in tension members shall be enclosed in spirals made of bars not less than 6 mm diameter with pitch not more than 100 mm.

(d) The lap length in compression shall be equal to the development length in compression, but not less than 24ϕ .

(e) When bars of two different diameter are to be spliced, the lap length shall be calculated on the basis of diameter of the smaller bar.

(f) When splicing of welded wire fabric is to carried out, lap splices of wires shall be made so that overlap measured between the extreme cross wires shall be not less than spacing of cross wires plus 100 mm.

(g) In case of bundled bars, lapped splices of bundled bars shall be made by splicing one bar at a time : such individual splices within a bundle shall be staggered.

Strength of Welds :

The following values may be used where the strength of weld has been proved by tests to be at least as great as that of the parent bars.

(a) Splices in compression:

For welded splices and mechanical connection, 100 percent of the design strength of joined bars.

(b) Splices in tension:

(1) 80% of the design strength of welded bars (100% if welding is strictly supervised and if at any c/s of the member not more than 20% of the tensile reinforcement is welded)

(2) 100% of the design strength of mechanical connection.

End Bearing Splices: End bearing splices should be used only for bars in compression. These are of square cut and concentric bearing ensured by suitable devices.

EXAMPLE-6.1

A SIMPLY SUPPORTED IS 25 cm X50cm and has 2 – 20 mm TOR bars going into the support. If the shear force at the center of the support is 110 KN at working loads, determine the anchorage length. assume M20 mix and Fe 415 grade TOR steel .

Solution:-

For a load factor equal to 1.5, the factored SF= 1.5 x 110=165 kN.

Assuming 25 mm clear cover to the longitudinal bars

Effective depth = 500- 25 – 20/2 = 465 mm.

Characteristic strength of TOR steel $\sigma_y = 415 \text{ N/mm}^2$

Moment of resistance $M_1 = 0.87 \sigma_y A_t (d - 0.42 x)$

$$x = \frac{0.87 \sigma_y A_t}{0.36 \sigma_{ck} b} = \frac{0.87 \times 415 \times 628}{0.36 \times 20 \times 250} = 126 \text{ mm} < x_m \quad \text{OK}$$

$$\text{or } M_1 = 0.87 \times 415 \times 2 \times \pi/4 \times 20^2 (465 - 0.42 \times 126) = 93.45 \times 10^6 \text{ Nmm}$$

Bond stress $\tau_{bd} = 1.2 \text{ N/mm}^2$ for M20 mix. It can be increased by 60% in case of TOR bars.

$$\text{Development length } L_d = \frac{\phi \sigma_s}{4 \tau_{bd}} = \frac{0.87 \times 415 \phi}{4 \times (1.6 \times 1.2)} = 47 \phi$$

If the bar is given a 90° bend at the centre of support, its anchorage value

$$L_o = 8 \phi = 8 \times 20 = 160 \text{ mm}$$

$$L_d \leq 1.3 M_1/V + L_o$$

$$47 \phi \leq \left[\frac{1.3 \times 93.45 \times 10^6}{165 \times 1000} \right] + 160$$

$$\text{or, } \phi \leq 19 \text{ mm}$$

Since actual bar diameter of 20 mm is greater than 19 mm, there is a need to increase the anchorage length. Let us increase the anchorage length L_o to 240 mm. It gives

$$\phi \leq 20.8 \text{ mm} \quad \text{OK}$$

The arrangement of 90° bend is shown in Fig. 8.19a.

Alternatively

Provide a U bend at the centre of support, its anchorage value,

$$L_o = 16 \phi = 320 \text{ mm}$$

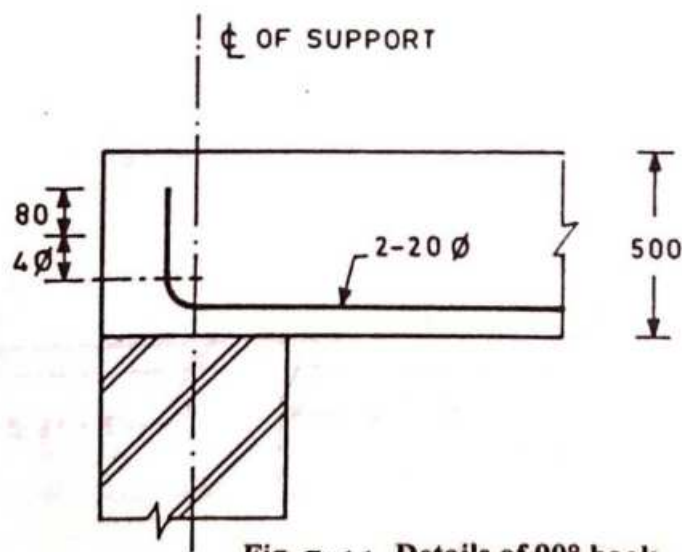

Fig. Ex 1.1 Details of 90° hook

$$L_d \leq 1.3 M_1/V + L_o.$$

$$47\phi \leq \left[\frac{1.3 \times 93.45 \times 10^6}{165 \times 1000} \right] + 320$$

$$\text{Or. } \phi \leq 22.47 \text{ mm}$$

Actual bar diameter provided is 20 mm < 22.47 mm.

The arrangement of U- Bend is shown in Fig-Ex 1.2.

In High strength reinforced bars U- Bend should be avoided as far as possible since they may be brittle and may fracture with bending.

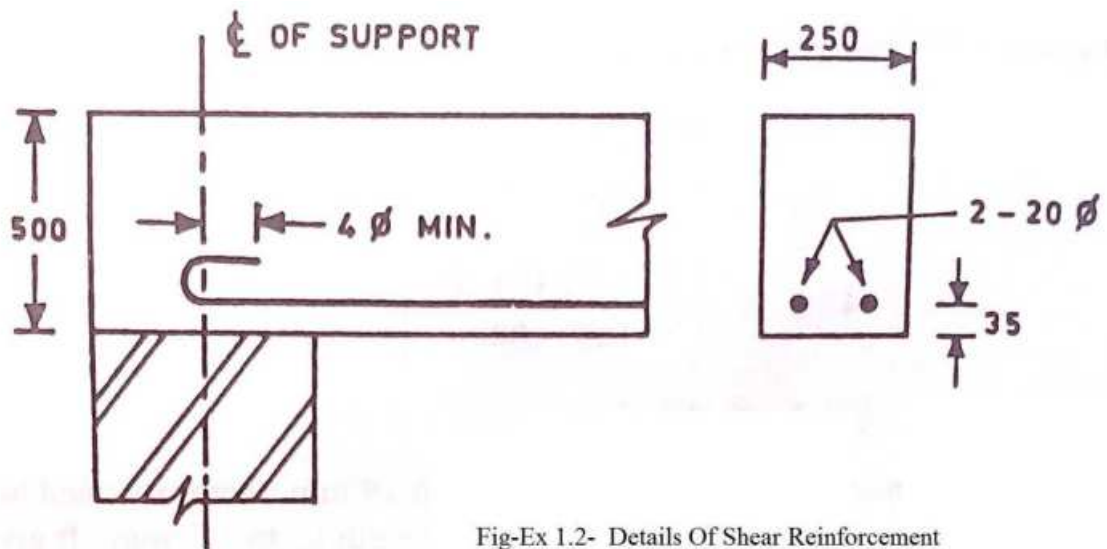

Fig-Ex 1.2- Details Of Shear Reinforcement

Example 5.2:

A continuous beam 25 cm X 40 cm carries 3-16 mm longitudinal bars beyond the point of inflection in the sagging moment region as shown in Fig.Ex 1.3,.If the factored SF at the point of inflection is 150 kN, $\sigma_{ck} = 20 \text{ N/mm}^2$ and $\sigma_y = 415 \text{ N/mm}^2$, check if the beam is safe in bond ?

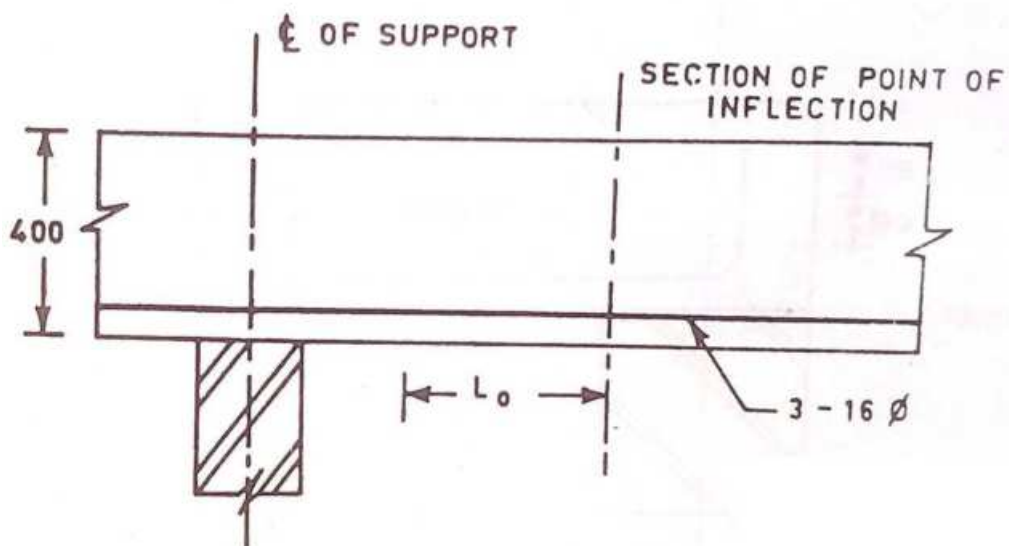

Fig- Ex 1.3 - Section of Continious Beam

$$\text{Depth of neutral axis } x = \frac{0.87 \sigma_y A_t}{0.36 \sigma_{ck} b} = \frac{0.87 \times 415 \times 3 \times \pi / 4 \times 16^2}{0.36 \times 20 \times 250}$$

$$= 120 \text{ mm} < x_m (= 0.48 d) \quad \text{OK}$$

$$\text{Moment of resistance } M_1 = 0.87 \sigma_y A_t (d - 0.42 x)$$

$$= 0.87 \times 415 \times 603 (367 - 0.42 \times 120) = 68.90 \times 10^6 \text{ Nmm}$$

$$\text{Development length } L_d = \frac{\sigma_s \phi}{4 \tau_{bd}}$$

$$\text{Bond stress } \tau_{bd} = 1.6 \times 1.2 \text{ N/mm}^2 \text{ for M20 mix and HSD steel}$$

$$\text{or } L_d = \frac{0.87 \times 415 \phi}{4 \times 1.6 \times 1.2} = 47 \phi$$

$$\text{Anchorage length } L_o = \text{greater of } d \text{ or } 12 \phi$$

$$= \text{greater of } 367 \text{ mm, or } 12 \times 16 = 192 \text{ mm}$$

$$= 367 \text{ mm}$$

$$L_d \leq \frac{M_1}{V} + L_o$$

$$\text{or } 47 \phi \leq \frac{68.9 \times 10^6}{150 \times 1000} + 367 \quad \text{or, } \phi \leq 17.6 \text{ mm}$$

Thus, 16 mm bars are safe in bond at the point of inflection.

CHAPTER 07

INTRODUCTION TO BEAM IN LIMIT STATE METHOD

Beams (LSM)

Control of deflection and ensuring lateral stability in beams as per Clause 23.2 & 23.3 of IS-456.

Design of singly reinforced rectangular beams, Design of doubly reinforced beams as per IS 456/SP- 16 for bending and shear

Design of T beams as per IS 456 for bending and shear

Course Objectives:

Control of deflection and ensuring lateral stability in beams as per Clause 23.2 & 23.3 of IS-456.

Introduction

Structures designed by limit state of collapse are of comparatively smaller sections than those designed employing working stress method. They, therefore, must be checked for deflection and width of cracks. Excessive deflection of a structure or part thereof adversely affects the appearance and efficiency of the structure, finishes or partitions. Excessive cracking of concrete also seriously affects the appearance and durability of the structure. Accordingly, cl. 35.1.1 of IS 456 stipulates that the designer should consider all relevant limit states to ensure an adequate degree of safety and serviceability. Clause 35.3 of IS 456 refers to the limit state of serviceability comprising deflection in cl. 35.3.1 and cracking in cl. 35.3.2. Concrete is said to be durable when it performs satisfactorily in the working environment during its anticipated exposure conditions during service. This lesson discusses about the different aspects of deflection of beams and the requirements as per IS 456. In addition, lateral stability of beams is also taken up while selecting the preliminary dimensions of beams.

Short- and Long-term Deflections

Short-term deflection refers to the immediate deflection after casting and application of partial or full service loads, while the long-term deflection occurs over a long period of time largely due to shrinkage and creep of the materials. The following factors influence the short-term deflection of structures:

- (a) magnitude and distribution of live loads,
- (b) span and type of end supports,
- (c) cross-sectional area of the members,
- (d) amount of steel reinforcement and the stress developed in the reinforcement,
- (e) characteristic strengths of concrete and steel, and
- (f) amount and extent of cracking

The long-term deflection is almost two to three times of the short-term deflection. The following are the major factors influencing the long-term deflection of the structures.

- (a) Humidity and temperature ranges during curing,
- (b) age of concrete at the time of loading, and
- (c) type and size of aggregates, water-cement ratio, amount of compression reinforcement, size of members etc., which influence the creep and shrinkage of concrete.

Control of deflection and ensuring lateral stability in beams as per Clause 23.2 & 23.3 of IS-456.

Clause 23.2 of IS 456 stipulates the limiting deflections under two heads as given below:

- (a) The maximum final deflection should not normally exceed span/250 due to all loads including the effects of temperatures, creep and shrinkage and measured from the as-cast level of the supports of floors, roof and all other horizontal members.
- (b) The maximum deflection should not normally exceed the lesser of span/350 or 20 mm including the effects of temperature, creep and shrinkage occurring after erection of partitions and the application of finishes.

It is essential that both the requirements are to be fulfilled for every structure.

Selection of Preliminary Dimensions :

The two requirements of the deflection are checked after designing the members. However, the structural design has to be revised if it fails to satisfy any one of the two or both the requirements. In order to avoid this, IS 456 recommends the guidelines to assume the initial dimensions of the members which will generally satisfy the deflection limits. Clause 23.2.1 stipulates different span to effective depth ratios and cl. 23.3 recommends limiting slenderness of beams, a relation of b and d of the members, to ensure lateral stability. They are given below:

(A) For the deflection requirements

Different basic values of span to effective depth ratios for three different support conditions are prescribed for spans up to 10 m, which should be modified under any or all of the four different situations:

- (i) for spans above 10 m,
- (ii) depending on the amount and the stress of tension steel reinforcement,
- (iii) depending on the amount of compression reinforcement,
- (iv) for flanged beams.

(B) For lateral stability as per clause 23.3 of IS-456

The lateral stability of beams depends upon the slenderness ratio and the support conditions. Accordingly cl. 23.3 of IS code stipulates the following:

(i) For simply supported and continuous beams, the clear distance between the lateral restraints shall not exceed the lesser of $60b$ or $250b^2/d$, where d is the effective depth and b is the breadth of the compression face midway between the lateral restraints.

(ii) For cantilever beams, the clear distance from the free end of the cantilever to the lateral restraint shall not exceed the lesser of $25b$ or $100b^2/d$.

Span/depth ratios and modification factors

Sl. No.	Items	Cantilever	Simply supported	Continuous
1	Basic values of span to effective depth ratio for spans up to 10 m	7	20	26
2	Modification factors for spans > 10 m	Not applicable as deflection calculations are to be done.	Multiply values of row 1 by 10/span in metres.	
3	Modification factors depending on area and stress of steel	Multiply values of row 1 or 2 with the modification factor from Fig.4 of IS 456.		
4	Modification factors depending as area of compression steel	Further multiply the earlier respective value with that obtained from Fig.5 of IS 456.		
5	Modification factors for flanged beams	(i) Modify values of row 1 or 2 as per Fig.6 of IS 456. Further modify as per row 3 and/or 4 where reinforcement percentage to be used on area of section equal to $b_f d$.		

Design of singly reinforced rectangular beams, Design of doubly reinforced beams as per IS 456/SP-16 for bending and shear

Design of singly reinforced rectangular beams as per IS 456/SP-16 for bending and shear

Types of Problems

Two types of problems are possible: (i) design type and (ii) analysis type.

In the design type of problems, the designer has to determine the dimensions b , d , D , A_{st} and other detailing of reinforcement, grades of concrete and steel from the given design moment of the beam. In the analysis type of the problems, all the above data will be known and the designer has to find out the moment of resistance of the beam

Design of the singly reinforced beam for bending

Type 1 :To design a singly reinforced rectangular section for a given width and applied factored moment

$$d_{bal} = \sqrt{\frac{M_u}{Q_{lim} X b}}$$

1. Assume 5% larger effective depth for $d \leq 500$ more & 10% larger depth for $1000 \text{ mm} \geq 500 \text{ mm}$
2. Assume one layer of 20mm diameter for (case 1) & two layers of 20mm diameter, bars (case 2)
3. If the clear cover to main reinf is 30mm Effective cover = $30+10$ (Assume 1 – Layer 20ϕ) = 40 mm
= $40+20$ (Assume 2 Layers 20ϕ)
4. Over all depth D over all = $d+40$ D over all = $d+60$
5. Now $d = D$ overall – 40mm (case1)
D overall – 60 mm (case-2)
6. Determine $\frac{M_u}{bd^2}$, p , A_{st} , $A_{st_{lim}}$
7. Select the bar size and number such that $A_{st} > A_{st \text{ required}}$ & also $A_{st} < A_{st_{lim}}$

Type 2 :- To find the steel area for a given factored moment

We know $d_{bal} = \sqrt{\frac{M_u}{Q_{lim} X b}}$ (Assume b)

For a given factored moment, width & depth of Section, final

$$m_{u_{lim}} = Q_{lim} x b d^2$$

$M_u < M_{u_{lim}}$, design as under reinforced Section

$M_u = M_{u_{lim}}$, design as balanced Section

$M_u > M_{u_{lim}}$, design as doubly reinforced Section

Design of the singly reinforced beam for shear

Shear reinforced In beams

The shear reinforcement shall be provided by the reinforcement which cross the cracks. These shear reinforcement. minimize the size of diagonal tension crack & carry diagonal tension stress from one side of crack to the other. The provision of shear reinforcement is made by the following forms.

- (i) Vertical Stirrups
- (ii) Inclined Stirrups
- (iii) Bent up bars along with Stirrups

Design for Shear

1. Find the Maximum S.F
2. Find the factored S.F (V_u)
3. Find the nominal shear stress $r_v = \frac{V_u}{bd}$
4. Obtain the design shear strength of concrete corresponding to percentage of tensile reinforcement provided for flexure from table 19, pg-73 IS 456.

Design shear strength (r_c) :- It is the capacity of concrete along with tensile reinforcement. To take the amount of shear force without providing any reinforcement for shear.

5. Find the excess shear force for which shear reinforcement is required to be provided i.e. V_{us} . $V_{us} =$ Applied shear – shear force to be resisted by concrete without any shear reinforcement.

$$V_{us} = V_u - r_c b d$$

6. To determine the quantity of shear reinforcement in terms of stirrup spacing as under.

- (i) For vertical stirrups

$$(ii) V_{us} = \frac{0.87 f_y A_{sv} \times d}{S_v}$$

V_{us} = Excess S.F to be resisted

A_{sv} = Area of shear reinforcement.

S_v = Spacing of stirrups

$$S_v = \frac{0.87 f_y A_{sv}}{d} V_{us}$$

- (iii) For inclined stirrups

$$V_{us} = \frac{0.87 f_y A_{sv} \times d (\sin \alpha + \cos \alpha)}{S_v}$$

Or

$$S_v = \frac{0.87 f_y A_{sv} d (\sin \alpha + \cos \alpha)}{V_{us}}$$

- (iv) For Bent up bars

$$V_{us} = 0.87 f_y A_{sv} \cdot \sin \alpha$$

IS 456 says the contribution of bent up bars towards shear resistance shall not exceed half of the shear resistance.

α = angle between bent up the inclined stirrups or bent up bar and total axis of member not less than 45°

Minimum shear reinforcement .

Spacing of shear stirrups should not exceed the following.

$$\frac{A_{sv}}{bS_v} \geq \frac{0.4}{0.87 f_y}$$

$$(i) S_v = \frac{0.87 f_y A_{sv}}{0.4 b}$$

(ii) 0.75 d (d = Effective depth)

(iii) 300 mm c/c distance

Example 1

A simply supported rectangular beam of 4 m span carries a uniformly distributed characteristic load including self-weight of 20 kN/m. The beam section is 230 mm x 450 mm overall. Design the beam for bending and shear. The materials are grade M20 concrete and HYSD reinforcement of grade Fe 415. The beam is suspended from the upper floor level.

PG 356 fig 9.5

Solution:

$$P_u = 1.5 \times 20 = 30 \text{ kN/m}$$

$$M_{u,max} = 30 \times \frac{4^2}{8} = 60 \text{ kNm and } V_{u,max} = 30 \times \frac{4}{2} = 60 \text{ kN.}$$

(a) Moment steel

The section is 230 mm x 450 mm overall. Assuming one layer of 16 mm diameter bars, effective depth shall be

$$d = 450 - 30(\text{cover}) - 8 (\text{centre of reinforcement}) = 412 \text{ mm.}$$

Depth required for singly reinforced section

$$= \sqrt{\frac{60 \times 10^6}{2.76 \times 230}}$$

$$= 308 \text{ mm} < 412 \text{ mm}$$

∴ Design as singly reinforced section.

$$\frac{M_u}{bd^2} = \frac{60 \times 10^6}{230 \times 412 \times 412} = 1.54$$

From SP 16 table no 2 $P_t = 0.474$

$$A_{st} = \frac{0.474 \times 230 \times 412}{100} = 449 \text{ mm}^2$$

Minimum steel required

$$A_s = \frac{0.205}{100} \times 230 \times 412 = 194 \text{ mm}^2$$

$$A_{sbal} = \frac{0.96}{100} \times 230 \times 412 = 910 \text{ mm}^2$$

$$\therefore 194 \text{ mm}^2 < A_{st, \text{ provided}} < 910 \text{ mm}^2.$$

Provide 4 no. 12mm # = 4x113 = 452 mm²

Let 2 bar be bent at 1.25 D

= 1.25 X 450 = 562.5 mm, say 600 mm, from the face of the support

Check for shear :

As support

$$V_u = 60 \text{ kN}$$

$$\tau_v = \frac{60 \times 10^3}{230 \times 412} = 0.633 \text{ N/mm}^2.$$

$$\frac{100 A_s}{bd} = \frac{2 \times 113 \times 100}{230 \times 412} = 0.238$$

$$\tau_c = 0.332 \text{ N/mm}^2 < 0.633 \text{ N/mm}^2.$$

∴ Shear design is necessary

Note that the critical section for checking the shear stress in this case is the face of the support (and not at distance d from the face of the support) because the reaction at support induces tension in end region.

As support 2 bent bars can be used to carry shear stress. These give a shear resistance of

$$\sin 45^\circ \times 2 \times 113 \times 0.87 \times 415 \times 10^{-3} = 57.69 \text{ kN.}$$

$$\tau_c bd = 0.332 \times 230 \times 412 \times 10^{-3} = 31.46 \text{ kN.}$$

$$V_{us} = V_u - \tau_c bd = 60 - 31.46 = 28.54 \text{ kN.}$$

Bent bars share 50% = 14.27 kN.

Stirrups provide 50% = 14.27 kN.

Using 6 mm ϕ two legged M.S. stirrups, spacing can be given by $\frac{0.87f_y A_{sv}d}{V_{us}}$

Where $A_{sv} = 2 \times 28 = 56 \text{ mm}^2$

$$\therefore S_v = \frac{0.87 \times 250 \times 56 \times 412}{14.27 \times 10^3} = 351 \text{ mm} \dots\dots\dots(1)$$

At distance of 550 mm from support, where two bars are bent

$$V_u = 60 - (0.55 \times 30) = 43.5 \text{ kN}$$

$$V_{us} = 43.5 - 31.46 = 12.04 \text{ kN}$$

This will give larger spacing than above.

Minimum shear reinforcement .

Spacing of shear stirrups should not exceed the following.

$$\frac{A_{sv}}{bS_v} \geq \frac{0.4}{0.87 f_y}$$

$$(i) S_v = \frac{0.87 f_y A_{sv}}{0.4 b}$$

(ii) $0.75 d$ (d = Effective depth)

(iii) 300 mm c/c distance

$$\text{Using 2legged 6 mm } \phi \text{ mild steel stirrup } S_v = \frac{0.87 \times 250 \times 56}{0.4 \times 232} = 132.4 \text{ mm}$$

For 230 mm wide beam minimum shear reinforcement is 6 mm ϕ about 130 mm c/c.....(2)

From (1) and (2) minimum shear reinforcement shall be provided, i.e., 6 mm ϕ about 130 mm c/c.

Design of doubly reinforced beams as per IS 456/SP-16 for bending and shear

DOUBLY REINFORCEMENT BEAMS

When the applied moment is greater than M.R of a singly reinforced section, then steel reinforcement is added in compression zone to increase the M.R of the section, then this is known as doubly reinforced section

There are three alternatives

- i. Increase the dimensions of the section i.e. depth
- ii. Higher grades of concrete can be increased to increase the M.R of the section.
- iii. Steel reinforcement. may be added in compression zone to increase the M.R of the section.

Design of doubly reinforced beams

Type -1: To find out reinforcement for flexure for a given section & factored moment.

- (i) Find out M_{ulim} & reinforcement A_{stlim} for a given section by using the equation

$$M_{ulim} = Q_{lim} \times bd^2$$

$$= 0.36f_{ck} b \cdot x_{umax} (d - 0.42x_{umax})$$

$$\& A_{stlim} = \frac{M_{ulim}}{0.87 f_y (d - 0.42 X_{umax})}$$

- (ii) Obtain moment $M_{u2} = M_u - M_{ulim}$

- (iii) Find out compression steel from equation $M_{u2} = A_{sc} (f_{sc} \cdot f_c)(d - d')$

Neglecting fcc, $A_{sc} = \frac{Mu_2}{f_{sc}(d-d')}$

- (iv) Corresponding A_{st} Tensile step A_{st2} can be found out from

$$A_{st2} = \frac{A_{sc} f_{sc}}{0.87 f_y}$$

(v) $A_{st} = A_{stlim} + A_{st2}$

- (vi) Provide the reinforcement

Example 2

Design a simply supported rectangular beam of size 230 mm x 600 mm overall for a super-imposed load of 46 kN/m. Span of the beam is 5 m. The materials are M 20 grade concrete and HYSD reinforcement of grade Fe 415.

Solution:

Self weight of beam = $0.3 \times 0.60 \times 25 = 3.45$ kN/m

Super-imposed load = $\frac{46.00 \text{ kN/m}}{\text{Total } 49.45 \frac{\text{kN}}{\text{m}}}$ say 50 kN/m

Factor load = $1.5 \times 50 = 75$ kN/m

$$M_u = \frac{5^2}{8} \times 75 = 243.4 \text{ kNm}$$

$$V_u = \frac{5}{2} \times 75 = 187.5 \text{ kN}$$

Moment steel:

Assuming 2 layers of 20 mm diameter bars

$$D = 600 - 30 - 20 - 10 = 540 \text{ mm}$$

$$\frac{Mu}{bd^2} = \frac{243.4 \times 10^6}{230 \times 540^2} = 3.63 > 2.76$$

∴ Doubly reinforced section

$$M_{u,lim} = 2.76 \times 230 \times 540^2 \times 10^{-6} = 185.10 \text{ kNm}$$

$$M_{u2} = 243.4 - 185.10 = 58.3 \text{ kNm.}$$

Let the compression reinforcement be provided at an effective cover of 40 mm

$$\frac{d'}{d} = \frac{40}{545} = 0.07, \text{ consider } \frac{d'}{d} = 0.1$$

Stress in compression steel, $f_{sc} = 353 \text{ N/mm}^2$ (refer to table f of S.P-16)

$$A_{sc} = \frac{Mu_2}{f_{sc}(d-d')} = \frac{58.3 \times 10^6}{353(540-40)} = 330 \text{ mm}^2$$

Corresponding tension steel

$$A_{st2} = \frac{A_{sc} f_{sc}}{0.87 f_y} = \frac{330 \times 353}{0.87 \times 415} = 323 \text{ mm}^2$$

$$A_{st1} = A_{st,lim} = P_{t,lim} \times \frac{bd}{100}$$

$$= 0.96 \times \frac{230 \times 540}{100} = 1192 \text{ mm}^2$$

$$A_{st} = A_{st1} + A_{st2} = 1192 + 323 \text{ mm}^2 = 1515 \text{ mm}^2$$

$$A_{sc} = 2-16 \# = 402 \text{ mm}^2$$

$A_{st} = 5-20\# = 1570 \text{ mm}^2$ (all straight). Provide 3 bars in first layers and 2 bars in second layer.

For designed section, equating total compression and total tension

$$0.36 f_{ck} b x_u + A_{sc} f_{sc} = 0.87 f_y A_{st}$$

$$0.36 \times 20 \times 230 x_u + 402 \times 353 = 0.87 \times 415 \times 1570$$

$$x_u = 256.6 \text{ mm}$$

$$x_{u,max} = 0.48d = 0.48 \times 540 = 259.2 \text{ mm}$$

$$x_u < x_{u,max}$$

Hence the beam is under reinforced section.

(b) Check for shear:

$$r_v = \frac{187.5 \times 10^3}{230 \times 540} = 1.51 \text{ N/mm}^2 < 2.8 \text{ N/mm}^2$$

$$\frac{100 A_s}{bd} = \frac{100 \times 1515}{230 \times 540} = 1.26$$

$$r_c = 0.672 \text{ N/mm}^2$$

As the ends are confined with compressive reaction, shear at distance d will be used for checking shear at support. At 540 mm, shear is equal to

Using 8 mm # two legged stirrups, spacing can be given by $\frac{0.87 f_y A_{sv} d}{V_{us}}$

$$\text{Where } A_{sv} = 2 \times 50 = 100 \text{ mm}^2$$

$$\therefore S_v = \frac{0.87 \times 415 \times 100 \times 540}{63.5 \times 10^3} = 307 \text{ mm} \dots\dots\dots(1)$$

At distance of 550 mm from support, where two bars are bent

$$V_u = 187.5 - (0.540 \times 75) = 147 \text{ kN}$$

$$V_{us} = 147 - 0.672 \times 230 \times 540 \times 10^{-3} = 63.5 \text{ kN}$$

This will give larger spacing than above.

Minimum shear reinforcement .

Spacing of shear stirrups should not exceed the following.

$$\frac{A_{sv}}{bS_v} \geq \frac{0.4}{0.87 f_y}$$

$$(i) S_v = \frac{0.87 f_y A_{sv}}{0.4 b}$$

$$(ii) 0.75 d \text{ (} d = \text{Effective depth)} = 0.75 \times 540 = 405 \text{ mm}$$

$$(iii) 300 \text{ mm c/c distance}$$

$$\text{Using 2legged 8 mm \# stirrup } S_v = \frac{0.87 \times 415 \times 100}{0.4 \times 230} = 392.4 \text{ mm}$$

For 230 mm wide beam minimum shear reinforcement is 8 mm # about 300 mm c/c.....(2)

Hence provide mm # about 300 mm c/c through out the beam.

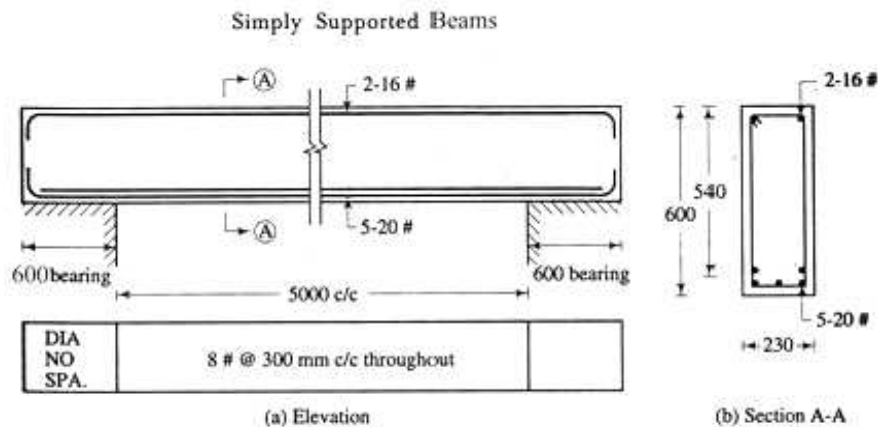

7.3:Design

of T beams as per IS 456 for bending and shear

DESIGN OF T BEAM

Case-1: To design the beam for a given loading condition

- (i) Fixe the width of the beam using architectural consideration. Also the width shall be sufficient to accommodate the reinforcement satisfying the requirement of spacing of bars
- (ii) Effective width of flange for T beam $= b_f = \frac{l_0}{6} + bw + 6Df$
- (iii) Assume overall depth D equal to 1/12 th to 1/10 of the span and subtracting effective concrete cover from overall depth, find out the effective depth d
- (iv) Assume lever arm $Z=d-D_f/2$
- (v) Find out the reinforcement $A_s = \frac{Mu}{0.87 \times f_y \times Z}$
- (vi) Provide the reinforcement as per requirement.
- (vii) Then find out $\frac{b_f}{b_w}$ and $\frac{D_f}{d}$ then from table 58 of S.P16 find out the value of $M_{ulim.T}$. And check whether under reinforced or over reinforcement assuming the position of neutral axis

If the moment of resistance is less than the applied moment, revise the section.

$$\text{When } D_f \leq \frac{3}{7} x_u$$

$$Mu = 0.36 f_{ck} b_w x_u (d - 0.42 x_u) + 0.446 f_{ck} (b_f - b_w) \times D_f (d - \frac{D_f}{2})$$

$$\text{When } D_f \geq \frac{3}{7} x_u$$

$$Mu = 0.36 f_{ck} b_w x_u (d - 0.42 x_u) + 0.446 f_{ck} (b_f - b_w) \times D_f (d - \frac{Y_f}{2})$$

$$\text{Where } Y_f = 0.15 x_u + 0.65 D_f$$

Design for Shear

7. Find the Maximum S.F
8. Find the factored S.F (V_u)
9. Find the nominal shear stress $r_v = \frac{V_u}{bd}$
10. Obtain the design shear strength of concrete corresponding to percentage of tensile reinforcement provided for flexure from table 19, pg-73 IS 456.

Design shear strength (r_c) :- It is the capacity of concrete along with tensile reinforcement. To take the amount of shear force without providing any reinforcement for shear.

11. Find the excess shear force for which shear reinforcement is required to be provided i.e. V_{us} . $V_{us} =$ Applied shear – shear force to be resisted by concrete without any shear reinforcement.

$$V_{us} = V_u - r_c bd$$

12. To determine the quantity of shear reinforcement in terms of stirrup spacing as under.

(v) For vertical stirrups

$$0.87 f_y A_{sv} \times d$$

$$(vi) V_{us} = \frac{0.87 f_y A_{sv} \times d}{S_v}$$

V_{us} = Excess S.F to be resisted

A_{sv} = Area of shear reinforcement.

S_v = Spacing of stirrups

$$S_v = \frac{0.87 f_y A_{sv}}{d} V_{us}$$

(vii) For inclined stirrups

$$V_{us} = \frac{0.87 f_y A_{sv} \times d (\sin \alpha + \cos \alpha)}{S_v}$$

Or

$$S_v = \frac{0.87 f_y A_{sv} d (\sin \alpha + \cos \alpha)}{V_{us}}$$

(viii) For Bent up bars

$$V_{us} = 0.87 f_y A_{sv} \cdot \sin \alpha$$

IS 456 says the contribution of bent up bars towards shear resistance shall not exceed half of the shear resistance.

α = angle between bent up the inclined stirrups or bent up bar and total axis of member not less than 45°

e Minimum shear reinforcement .

Spacing of shear stirrups should not exceed the following.

$$\frac{A_{sv}}{b S_v} \geq \frac{0.4}{0.87 f_y}$$

$$(i) \ S_b = \frac{0.87 f_y A_{sv}}{0.4 b}$$

(ii) 0.75 d (d = Effective depth)

(iii) 300 mm c/c distance

Design a simply supported tee beam of span 7 m and spaced at 3 m centres. The thickness of slab is 100 mm and total characteristic load including self-weight of the beam is 30 kN/m. The overall size of the beam is 230 mm \times 600 mm. The materials are M20 grade concrete and HYSD reinforcement of grade Fe 415.

Solution:

$$\text{Factored load} = 1.5 \times 30 = 45 \text{ kN/m}$$

$$\text{Factored moment } M_u = 45 \times \frac{7^2}{8} = 275.6 \text{ kNm}$$

$$\text{Factored shear } V_u = 45 \times \frac{7}{2} = 157.5 \text{ kN.}$$

(a) *Moment steel:*

Assuming 2 layers of 20 mm # bars

$$d = 600 - 30 - 20 - 10 = 540 \text{ mm.}$$

As a preliminary design assume lever arm

$$z = d - \frac{D_f}{2} = 540 - \frac{100}{2} = 490 \text{ mm.}$$

$$A_{st} = \frac{M_u}{0.87 f_y z} = \frac{275.6 \times 10^6}{0.87 \times 415 \times 490} = 1558 \text{ mm}^2.$$

$$\text{Provide } 5\text{-}20 \text{ mm \#} = 5 \times 314 = 1570 \text{ mm}^2.$$

The section is now checked for moment of resistance.

$$\begin{aligned} b_f &= \frac{l_0}{6} + b_w + 6 D_f > 3000 \\ &= \frac{7000}{6} + 230 + 6 \times 100 = 1996 \text{ mm.} \end{aligned}$$

Use

$$b_f = 1990 \text{ mm}$$

$$\begin{aligned} F_{tc} &= 0.36 f_{ck} b_f D_f \\ &= 0.36 \times 20 \times 1990 \times 100 \times 10^{-3} = 1432.8 \text{ kN} \end{aligned}$$

$$\begin{aligned} F_{ts} &= 0.87 f_y A_{st} \\ &= 0.87 \times 415 \times 1570 \times 10^{-3} = 566.8 \text{ kN} \end{aligned}$$

$$F_{tc} > F_{ts}$$

\therefore Neutral axis lies in flange.

Equating the forces

$$\text{Total compression} = \text{total tension}$$

$$0.36 f_{ck} b_f x_u = 0.87 f_y A_{st}$$

$$0.36 \times 20 \times 1990 x_u = 0.87 \times 415 \times 1570$$

$$\therefore x_u = 39.56 \text{ mm}$$

$$x_{u,max} = 0.48 d = 0.48 \times 540 = 259.2 \text{ mm}$$

$$x_u < x_{u,max}$$

\therefore Under-reinforced section.

$$\begin{aligned}
 M_u &= 0.87 f_y A_{st} (d - 0.42 x_u) \\
 &= 0.87 \times 415 \times 1570 \times (540 - 0.42 \times 39.56) \times 10^{-6} \\
 &= 296.7 \text{ kNm} > 275.6 \text{ kNm} \dots\dots\dots (\text{O.K.})
 \end{aligned}$$

Let 2 bars bent up at $1.25 \times 600 = 750$ mm from the face of the support.

(b) *Check for devel*

At support, $A_{st} = 3 \times 314 = 942 \text{ mm}^2$.

$$0.36 f_{ck} b_f x_u = 0.87 f_y A_{st}$$

$$\therefore 0.36 \times 20 \times 1990 x_u = 0.87 \times 415 \times 942$$

$$x_u = 23.74 \text{ mm.}$$

$$M_{u1} = 0.87 f_y A_{st} (d - 0.42 x_u)$$

$$= 0.87 \times 415 \times 942 \times (540 - 0.42 \times 23.74) \times 10^{-6}$$

$$= 180.2 \text{ kNm}$$

$$V_u = 157.5 \text{ kN.}$$

As the ends of reinforcement are confined with compressive reaction, we have

$$1.3 \frac{M_{u1}}{V_u} + L_0 \geq L_d$$

Assume $L_0 = 12 \#$

$$\therefore 1.3 \times \frac{180.2 \times 10^6}{157.5 \times 10^3} + 12 \# \geq 47 \#$$

$$\therefore 42.5 \geq \#$$

$$\#_{\text{provided}} = 20 \text{ mm} \dots\dots\dots (\text{Safe})$$

(c) *Check for shear:*

As the ends are confined by compressive reaction, shear at distance d will be used at the support.

$$\therefore V_u = 157.5 - 0.540 \times 45 = 133.2 \text{ kN}$$

$$\frac{100 A_s}{b d} = \frac{100 \times 942}{230 \times 540} = 0.758$$

$$\tau_c = 0.562 \text{ N/mm}^2$$

$$\tau_v = \frac{133.2 \times 10^3}{230 \times 540} = 1.06 \text{ N/mm}^2 > \tau_c$$

\(\therefore\) Shear design is necessary.

2-20 # bars can resist a shear of

$$0.87 \times 415 \times 2 \times 314 \times \sin 45^\circ \times 10^{-3} = 160.32 \text{ kN.}$$

$$V_{us} = V_u - \tau_c b d$$

$$= 133.2 - 0.562 \times 230 \times 540 \times 10^{-3} = 63.40 \text{ kN.}$$

Bent bars share 50 % = 31.7 kN

Stirrups share 50 % = 31.7 kN.

Using 6 mm ϕ M.S. two-legged stirrups, $A_{sv} = 56 \text{ mm}^2$

Use 2-10 # as anchor bars. The designed section is shown in fig.

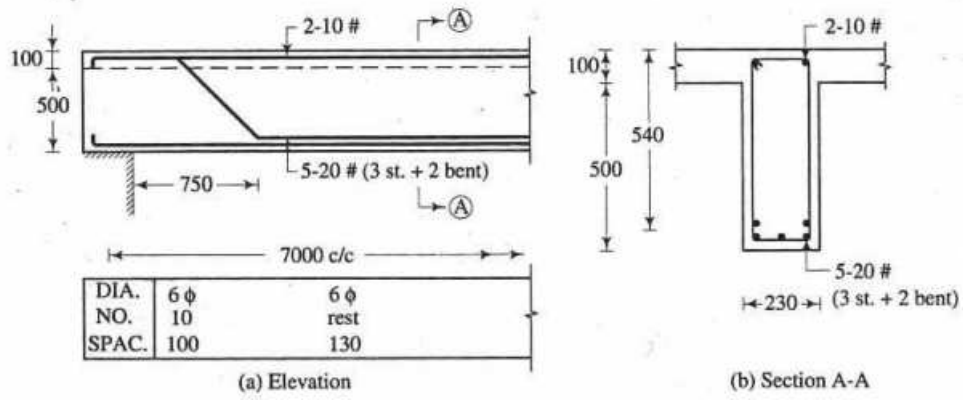

CHAPTER 08

INTRODUCTION TO SLABS BY LIMIT STATE METHOD

SLABS

- : One way slab & two way slab
- : One way & cantilever slabs as per IS-456 for bending & shear.8.3:
Explain the action of two way slabs with deflected shape.
- : Provision for two way slab as per IS-456-20008.4.1: Middle strip & edge strip
- : B.M Co-Efficient
- : Torsion reinforcement
- : Design of two way slab as per IS-456-2000 & SF-16 hand hook
- : Check for **deflection**, development length & reinforcement. Requirement & spacing as per Sp-16 & IS-456

Slabs: Slabs are plate elements & carry loads primarily by flexure. They usually carry Vertical loads

Classification of Slab:

1. One way spanning slab
2. Two-way spanning slab
3. Flat slab
4. Grid slab
5. Circular and other shapes
6. Ribbed slab

One way spanning slab: The slab supported on two opposite supports is a one way spanning slab.

On the other way a slab which transfer is load on one of the set of two opposite edge supports is called one-way slab. In this case l_y/l_x is greater than two.

Two way spanning Slab: The Slab which is supported on all four edges and if $l_y \leq 2l_x$ slabs bend in both directions. Such slabs are called two way spanning slab.

$$\frac{l_y}{l_x} < 2$$

One way & cantilever slabs as per IS: 456 for bending & shear. One way spanning slab

1. Effective Span = Clear Span + Effective depth
or

Centre to centre of Support whichever is less

Moment Steel: The reinforcement In the direct of span is known as moment steel. The moment steel is known as main reinforcement.

Distribution Steel: The reinforcement perpendicular to the main reinforcement. Is known as distribution steel & placed in second layer. This reinforcement resists temp & shrinkage stresses, keeps the main reinforcement in position and distributes the concentrated or non uniform loads throughout the slab.

For a continuous slab at support, top reinforcement is provided as main steel to resist negative B.M.

$$\text{Spacing of slab bar} = \frac{\text{area of one bar} \times 1000}{\text{required area in mm}^2 \text{ per meter}}$$

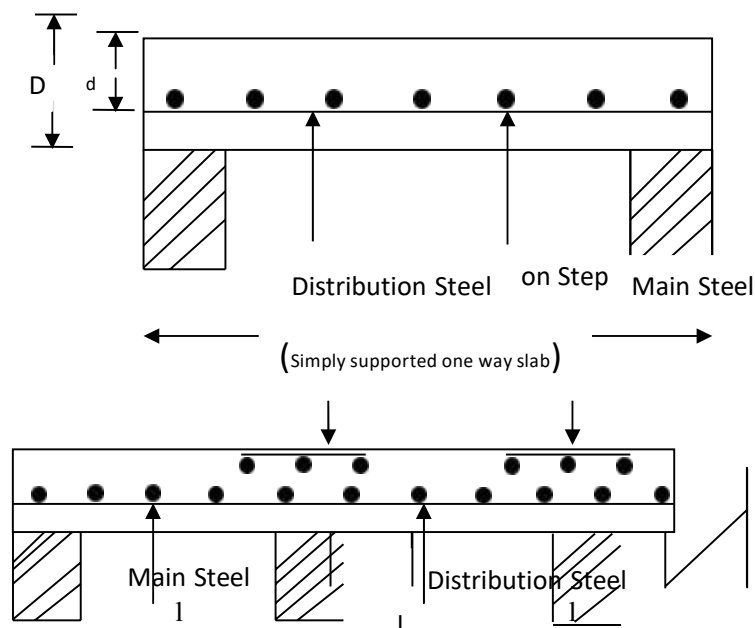

2. Reinforcement requirement

- (i) **Minimum reinforcement:-** The reinforcement in either direction in slabs shall not be less than 0.15% of the total c/s area. For HYSD bars, it shall not be less than 0.12%. thus in slabs, minimum reinforcement less than $0.85/f_y$ is permissible .
- (ii) **Maximum diameter:** The diameter of reinforcing bar shall not exceed $1/8^{\text{th}}$ the total thickness of slab.
- (iii) **Minimum diameter:** For main bars, minimum diameter shall be 10mm for plain bars & 8 mm for deformed bar for distribution bars, the minimum diameter shall be 6mm

Shear Stress:

$$\text{Design shear strength} = K r_c c_{\max}$$

$$\text{Nominal shear stress} \leq 0.5 \tau_{c \max}$$

This shall be checked

Deflection: It shall be checked as per beam

Cracking:

- (i) The horizontal distance between parallel main reinforcement shall not be more than 3 times the effective depth of a solid slab or 300mm whichever is smaller.
- (ii) The horizontal distance between parallel reinforcement bars against shrinkage & temperature shall not be more than 5 times the effective depth of a solid slab or 450 mm whichever is smaller.

Cover: For mild exposure, clear over = 20mm

When $\phi \leq 10$ mm clear cover = 15mm

$\phi > 12$ mm, clear cover = 20mm

Development Length:

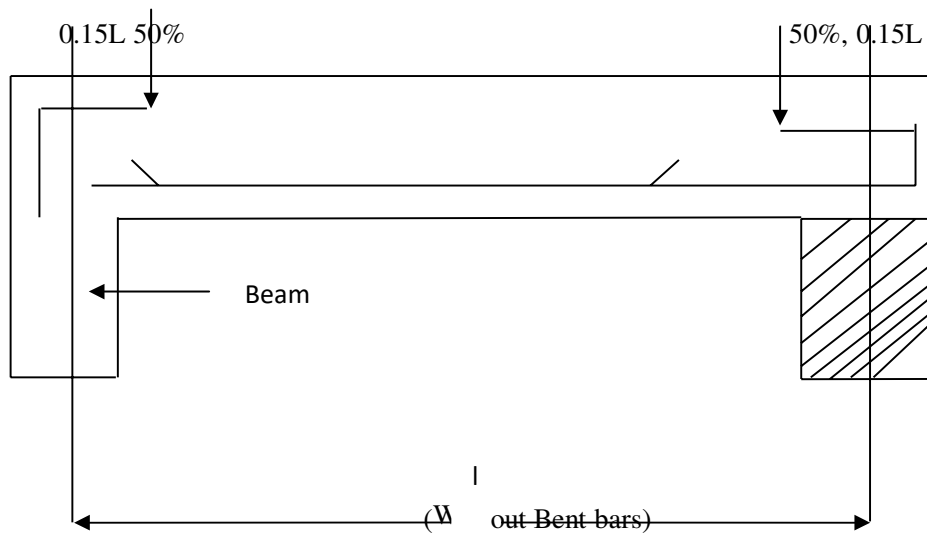

(Typical details of simply supports slab)

The bars can be bent up or curtailed only if continuing bars provide minimum reinforcement. & check for development length is satisfied.

Example

A simply supported one-way slab of clear span 3.0 m is supported on masonry walls of thickness 350 mm. Slab is used for residential loads. Design the slab. The materials are grade M 20 concrete and HYSD reinforcement of grade Fe 415. Live load shall be 2 kN/m².

Solution:

Depth of slab: The first trial of depth of slab can be arrived at by considering deflection criterion. Assuming percentage of steel reinforcement, find out modification factor as explained in art. 8-1. Percentage of steel depends on the loading on slab. A designer, after some practice will be able to find out his own thumb rules for the trial depth.

Assume 0.30 per cent steel as a first trial with service stress of $0.58 f_y = 0.58 \times 415 = 240 \text{ N/mm}^2$. Basic $\frac{\text{span}}{d}$ ratio = 20. Also modification factor from fig. 8-1 is 1.45.

Then permissible $\frac{\text{span}}{d}$ ratio = $20 \times 1.45 = 29$. The depth $d = \frac{3100}{29} = 106.9 \text{ mm}$. Considering mild exposure and maximum diameter of reinforcement be 12 mm, clear cover = 15 mm. Therefore $D = 106.9 + 6 + 15 = 127.9 \text{ mm}$.

Assume 130 mm overall depth of slab.

$$DL = 0.13 \times 25 = 3.25 \text{ kN/m}^2$$

$$\text{Floor finish} = 1.00 \text{ kN/m}^2$$

$$\text{Live load} = \underline{2.00 \text{ kN/m}^2}$$

$$\text{Total} \quad 6.25 \text{ kN/m}^2$$

$$\text{Factored load} = 1.5 \times 6.25 = 9.4 \text{ kN/m}^2.$$

Effective span (1) $3000 + 350 = 3350 \text{ mm c/c supports}$

(2) $3000 + 110 \text{ (effective depth)} = 3110 \text{ mm}$.

Use 3.11 m effective span.

Moment and shear:

Consider 1 m length of slab

\therefore load = 9.4 kN/m.

$$\text{Maximum moment} = 9.4 \times \frac{3.11^2}{8} = 11.36 \text{ kNm.}$$

$$\text{Maximum shear} = 9.4 \times \frac{3}{2} = 14.1 \text{ kN (based on clear span).}$$

Effective depth required for flexure L_x

$$= \sqrt{\frac{11.36 \times 10^6}{1000 \times 2.76}} = 64.15 \text{ mm.}$$

($Q = 2.76$ for M 20 mix and Fe 415 steel)

$$d_{\text{provided}} = 130 - 15 \text{ (cover)} - 5 \text{ (assume 10 } \phi \text{ bar)}$$

$$= 110 \text{ mm} \dots\dots\dots \text{(O.K)}$$

Design for flexure:

$$\frac{M_u}{b d^2} = \frac{11.36 \times 10^6}{1000 \times 110^2} = 0.939$$

$$p_t = \frac{100 A_{st}}{b d} = 0.281$$

$$\therefore A_{st} = \frac{0.281 \times 1000 \times 110}{100} = 309 \text{ mm}^2.$$

Provide 8 mm # about 150 mm c/c = 335 mm².

Note that use of design tables give correct answer for steel required.

Half the bars are bent at $0.1 l = 0.1 \times 3100 = 310 \text{ mm}$.

Remaining bars provide 167.5 mm² area.

$$\frac{100 A_s}{b D} = \frac{100 \times 167.5}{1000 \times 130} = 0.129 > 0.12$$

i.e., remaining bars provide minimum steel. Thus half the bars may be bent up

Distribution steel = $\frac{0.15}{100} \times 1000 \times 130 = 195 \text{ mm}^2$, using mild steel.

Maximum spacing $5 \times 100 = 500$ or 450 mm, i.e., 450 mm.

Provide 6 mm ϕ about 140 mm c/c = 202 mm².

Check for shear:

For bars at support

$$\text{correct } d = 130 - 15 - 4$$

$$= 111 \text{ mm}$$

$$\frac{100 A_s}{b D} = \frac{100 \times 167.5}{1000 \times 111} = 0.15.$$

For slab upto 150 mm thickness, $k = 1.3$

τ_c from table 7-1 = 0.28 N/mm².

Design shear strength

$$= k \tau_c = 1.3 \times 0.28$$

$$= 0.364 \text{ N/mm}^2.$$

$$\text{Actual shear stress} = \frac{13.5 \times 10^3}{1000 \times 111} = 0.122 \text{ N/mm}^2 < 0.364 \text{ N/mm}^2 \dots\dots \text{(safe)}$$

Check for development length:

Refer to fig. 10-5.

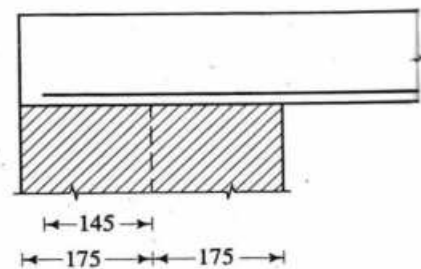

Details at support for bottom bars
FIG. 10-5

$L_0 = 145$ mm. L_0 is limited to $12 \phi = 96$ mm or
 $d = 100$ mm, whichever is greater.

$L_0 = 100$ mm.

For continuing bars, $A_s = 167.5$ mm². Also, the ends of the reinforcement are confined by compressive reaction.

$$M_{u1} = 0.87 f_y A_{st} d \left(1 - \frac{f_y A_{st}}{b d f_{ck}} \right)$$

$$M_{u1} = 0.87 \times 415 \times 167.5 \times 111 \left(1 - \frac{415 \times 167.5}{1000 \times 111 \times 20} \right) \times 10^{-6}$$

$$= 6.5 \text{ kNm.}$$

$$V_u = 13.5 \text{ kN.}$$

$$1.3 \frac{M_{u1}}{V_u} + L_0 \geq L_d \quad \text{where } L_d = 47 \#$$

$$1.3 \times \frac{6.5 \times 10^6}{13.5 \times 10^3} + 100 \geq 47 \#$$

or $15.4 \text{ mm} \geq \# \dots\dots\dots (\text{O.K.})$

Check for deflection :

$$\text{Basic } \frac{\text{span}}{d} \text{ ratio} = 20$$

$$p_t = \frac{100 \times 335}{1000 \times 111} = 0.3$$

$$\text{service stress} = 0.58 \times 415 \times \frac{303}{335} = 218 \text{ N/mm}^2.$$

$$\text{modification factor} = 1.62$$

$$\text{permissible } \frac{\text{span}}{d} \text{ ratio} = 20 \times 1.62 = 32.4$$

$$\text{actual } \frac{\text{span}}{d} \text{ ratio} = \frac{3100}{111}$$

$$= 28 < 32.4 \dots\dots\dots (\text{O.K.})$$

Note: The depth could be slightly reduced. Try with $D = 125$ mm from beginning and rework the problem

Check for cracking:

Maximum spacing permitted for main reinforcement

$$= 3 \times 100 = 300 \text{ mm.}$$

Actual spacing = 150 mm < 300 mm $\dots\dots\dots (\text{O.K.})$

For distribution steel, maximum spacing permitted

$$= 5 \times 100$$

$$= 500 \text{ or } 450 \text{ mm, i.e., } 450 \text{ mm.}$$

Spacing provided = 150 m $\dots\dots\dots (\text{O.K.})$

For tying the bent bars at top, 6 mm ϕ about 150 mm c/c distribution steel shall be provided.

Sketch: The cross-section of the slab

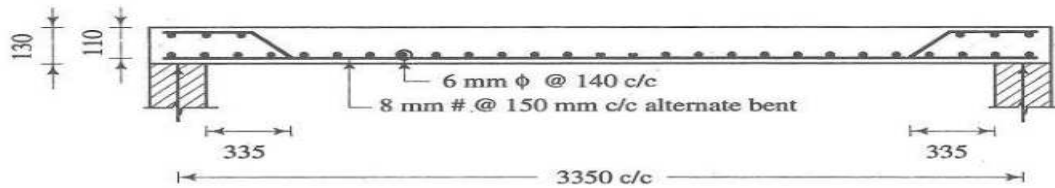

Design the slab S2 – S1 of above figure , if it is to be used for residential purpose at the free end of slab S1 there is a concrete parapet of 75mm thick and 1 m high. The materials are M20 grade concrete and HYSD reinforcement of grade Fe 415 . Use IS:875 for live loads.

Solution

Estimation of loads:

For slab S2 live load shall be 2 kN/m². For slab s1 which is a balcony slab live load shall be 3 kN/m². Assume 120 mm thick slab.

Slab S ₂ :	Self load = 0.12 × 25	= 3 + 0 kN/m ²
	Floor finish	= 1 + 0 kN/m ²
	Live load	= 0 + 2 kN/m ²
	Total	= <u>4 + 2 kN/m²</u>

$$P_u = 1.5(4+2)$$

$$= (6+3) \text{ kN/m}^2$$

Slab ₁ :	Self load	= 3 + 0 kN/m ²
	Floor finish	= 1 + 0 kN/m ²
	Live load	= <u>0 + 3 kN/m²</u>
	Total	= 4 + 3 kN/m ²

$$P_u = 1.5(4+3)$$

$$= 6+4.5 \text{ kN/m}^2$$

Weight of parapet

$$0.075 \times 25 \times 1 = 1.875 \text{ kN/m.}$$

$$p_u = 1.5 \times 1.875 = 2.8 \text{ kN/m.}$$

Analysis :

Consider 1m long strip.

1 To get maximum positive moment in slab s2 only dead load on slab s1 and total load on slab s2 shall be considered. The parapet load is a dead load but will not be considered as sometimes the owner of the building or architect may change his mind and would provide simply a railing.

Considering above figure

$$\text{Cantilever moment} = \frac{1.2^2}{2} \times 6 = 4.32 \text{ kNm.}$$

$$\text{Reaction at A} = \frac{9 \times 3}{2} - \frac{4.32}{3} = 12.06 \text{ kN}$$

$$\text{Point of zero shear from A} = \frac{12.06}{9} = 1.34 \text{ m.}$$

$$\begin{aligned} \text{Maximum positive moment} &= 12.06 \times 1.34 - \frac{1.34^2}{2} \times 9 \\ &= 16.16 - 8.08 \text{ kNm.} \end{aligned}$$

To check shear and development length at A, shear may be considered as 12.06 kN. Note that for the cantilever, clear span is considered

2 To get maximum negative moment and maximum shear at B , the slab is loaded with full loads

$$\begin{aligned} \text{Maximum negative moment} &= \frac{1.2^2}{2} \times 10.5 + 1.2 \times 2.8 \\ &= 7.56 + 3.36 = 10.92 \text{ kNm.} \end{aligned}$$

$$\text{Maximum shear at B, } V_u, BA = \frac{9 \times 3}{2} + \frac{10.92}{3} = 13.5 + 3.64 = 17.14 \text{ kN}$$

$$V_u, BC = 10.15 \times 1.2 + 2.8 = 15.4 \text{ kN.}$$

C) Moment steel:

Maximum moment = 10.92 kN.

$$d_{\text{required}} = \sqrt{\frac{10.92 \times 10^6}{1000 \times 2.76}} = 62.9 \text{ mm}$$

$$d_{\text{provided}} = 120 - 15 - 5 \text{ (assume 10\# bar)}$$

$$= 100 \text{ mm} \dots \dots \dots \text{ (O.K)}$$

$$\frac{M_u}{bd^2} (+) = \frac{8.08 \times 10^6}{1000 \times 100 \times 100} = 0.81$$

$$P_t = 0.236$$

$$A_{st} (+) = \frac{0.236 \times 1000 \times 100}{100} = 2.36 \text{ mm}^2$$

$$\frac{M_u}{bd^2} (-) = \frac{10.92 \times 10^6}{1000 \times 100 \times 100} = 1.09$$

$$P_t = 0.324$$

$$A_{st} (-) = \frac{0.324 \times 1000 \times 100}{100} = 324 \text{ mm}^2$$

For positive moment provide 8 mm # about 170 mm c/c giving 294 mm² alternate bent up and for negative moment provide 8 mm # about 340 mm c/c (bent bar extended) + 10 mm # 340 mm c/c giving 378 mm² area . The arrangement of reinforcement is shown in the below figure.

Note that at simple support, the bars are bent at 0.1 L whereas at continuity of slab it is bent at 0.2 L.

$$\text{Minimum steel} = \frac{0.12}{100} \times 1000 \times 120 = 144 \text{ mm}^2 .$$

Remaining positive moment bars give $A_s = \frac{294}{2} = 147 \text{ mm}^2$ Thus bar can be bent up.

$$\text{Distribution steel} = \frac{0.15}{100} \times 1000 \times 120 = 180 \text{ mm}^2 .$$

Provide 6 mm # about 150 mm c/c = 187 mm² .

For negative moment reinforcement

$$L_d = 47 \#$$

$$L_d = 47 \times \frac{(8+10)}{2} = 423 \text{ mm}.$$

The bars must be anchored upto 423 mm. also they should be extended upto 12 # beyond the point of contraflexure, which may be found out . Alternatively as a thumb rule, a bar shall be given an anchorage equal to the length of the cantilever. Adopting this, carry the top bars upto 1200 mm in the internal span. This is shown in above figure.

d) Check for Development length :

$$\begin{aligned} \text{At A, } M_{ul} &= 0.87 f_y A_{st} \left(d - \frac{f_y A_{st}}{bf_c k} \right) \\ &= 0.87 \times 415 \times 147 \left(100 - \frac{415 \times 417}{1000 \times 20} \right) \times 10^{-6} \\ &= 5.15 \text{ kNm.} \\ V_u &= 12.06 \text{ kN.} \end{aligned}$$

Consider $L_0 = 8 \#$

Then $1.3 \frac{M_{ul}}{V_u} + L_0 \geq L_d$

$$1.3 \times \frac{5.15 \times 10^6}{12.06 \times 10^3} + 8 \# \geq 47 \#$$

At B, $M_{ul} = 5.15 \text{ kNm}$.

Near point of contraflexure, i.e. $0.15 L$ from B

$$V_u = 17.14 - 0.45 \times 9 = 13.09 \text{ kN}$$

$$1.3 \times (5.15 \times 10^6 / 13.09 \times 10^3) + 8 \# \geq 47 \#$$

$$\# \leq 13.11 \text{ mm}$$

Check for Shear

Span AB: At A, $V_{u,AB} = 12.06 \text{ KN}$

At B, shear at point of contraflexure = 13.09 kN

Hence $V_u = 13.09 \text{ KN}$

$$\text{Shear stress } \tau_v = 13.09 \times 10^3 / 1000 \times 100 = 0.131 \text{ N/mm}^2$$

$$\frac{100 A_{Es}}{bd} = 100 \times 147 / 1000 \times 100 = 0.147$$

$$\tau_c = 0.28$$

$$k \times \tau_c = 0.28 \times 1.3 = 0.364 \text{ N/mm}^2 > \tau_v$$

Span BC

$$\therefore V_u = 17.14 \text{ KN}$$

$$\text{Shear stress } \tau_v = 17.14 \times 10^3 / 1000 \times 100 = 0.171 \text{ N/mm}^2$$

$$\frac{100 A_{Es}}{bd} = 100 \times 378 / 1000 \times 100 = 0.378$$

$$\tau_c = 0.28$$

$$k \times \tau_c = 0.421 \times 1.3 = 0.547 \text{ N/mm}^2 > \tau_v$$

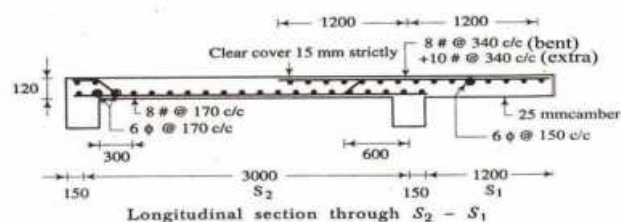

Two way Slabs:

The two way spanning slab

Occurs when the slab is supported

On all four edges

When $\frac{L_y}{L_x} < 2$, it is called two way slab.

Design

$$M_x = \alpha_x \cdot w \cdot L_x^2$$

$$M_y = \alpha_y \cdot w \cdot l_y^2$$

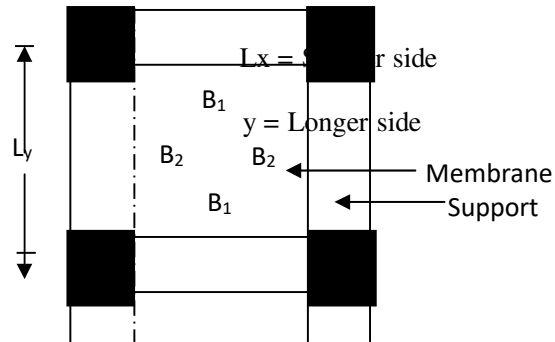

M_x, M_y = Moments on strips of unit width

spanning L_x & L_y respectively.

α_x, α_y = Co-efficient

= L_x, L_y = Lengths of shorter span & Longer span

Respectively

W = Total design load per unit area. IS -456 also states that at least 50% of the tension reinforcement. Provided at mid span intend to within 0.1 L_x or 0.1 L_y of the support.

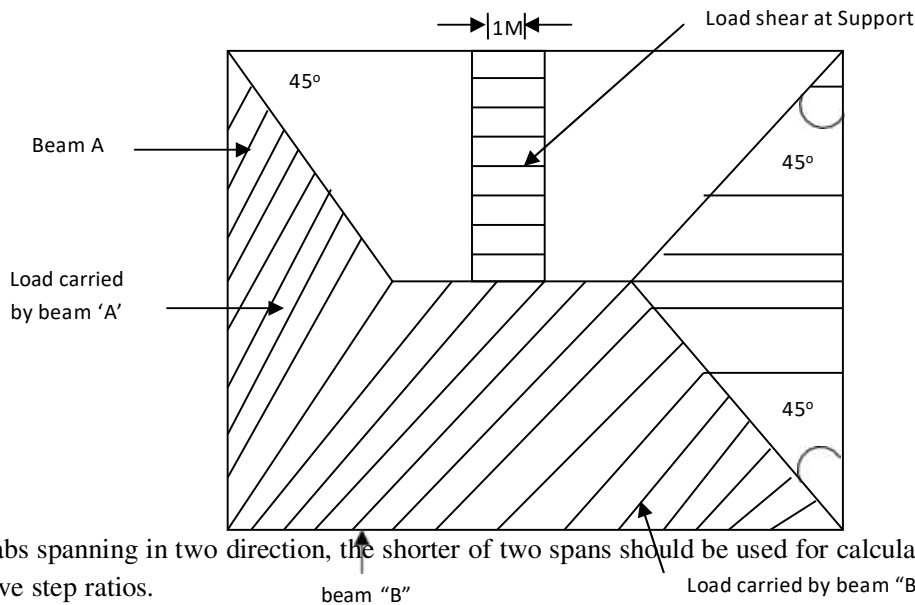

For slabs spanning in two direction, the shorter of two spans should be used for calculating the span to effective step ratios.

For two way slabs for span up to 3.5 with mild steel reinforcement. $\frac{span}{d} = 35$ for simply supported slabs

$\frac{span}{d} = 40$ for continuous slab for HYSD of grade Fe 415, there values are multiplied by 0.8.

Provison two way slab as per IS 456:2000

Middle Strip and edge strip

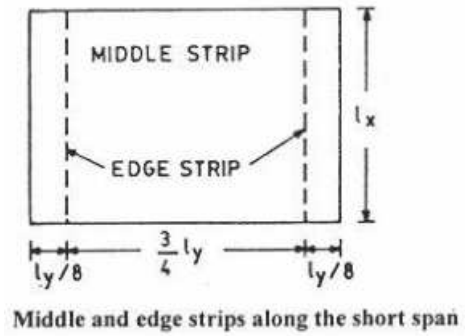
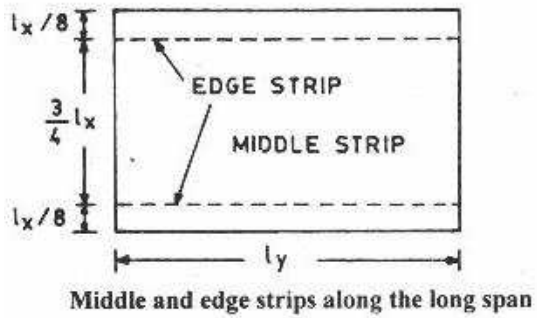

Bending moment Coefficients with torsion reinforcement

Table 8.6 Maximum bending moments of Problem 8.2 For	Short span			Long span
	α_x	M_x (kNm/m)	α_y	M_y (kNm/m)
Negative moment at continuous edge	0.075	18.6	0.047	11.66
Positive moment at mid-span	0.056	13.89	0.035	8.68

Table 26 Bending Moment Coefficients for Rectangular Panels Supported on Four Sides with Provision for Torsion at Corners
(Clauses D-1.1 and 24.4.1)

Case No.	Type of Panel and Moments Considered	Short Span Coefficients α_x (Values of l_y/l_x)								Long Span Coefficients α_y for All Values of
		1.0 (3)	1.1 (4)	1.2 (5)	1.3 (6)	1.4 (7)	1.5 (8)	1.75 (9)	2.0 (10)	l_y/l_x (11)
1	<i>Interior Panels:</i> Negative moment at continuous edge Positive moment at mid-span	0.032 0.024	0.037 0.028	0.043 0.032	0.047 0.036	0.051 0.039	0.053 0.041	0.060 0.045	0.065 0.049	0.032 0.024
2	<i>One Short Edge Continuous:</i> Negative moment at continuous edge Positive moment at mid-span	0.037 0.028	0.043 0.032	0.048 0.036	0.051 0.039	0.055 0.041	0.057 0.044	0.064 0.048	0.068 0.052	0.037 0.028
3	<i>One Long Edge Discontinuous:</i> Negative moment at continuous edge Positive moment at mid-span	0.037 0.028	0.044 0.033	0.052 0.039	0.057 0.044	0.063 0.047	0.067 0.051	0.077 0.059	0.085 0.065	0.037 0.028
4	<i>Two Adjacent Edges Discontinuous:</i> Negative moment at continuous edge Positive moment at mid-span	0.047 0.035	0.053 0.040	0.060 0.045	0.065 0.049	0.071 0.053	0.075 0.056	0.084 0.063	0.091 0.069	0.047 0.035
5	<i>Two Short Edges Discontinuous:</i> Negative moment at continuous edge Positive moment at mid-span	0.045 0.035	0.049 0.037	0.052 0.040	0.056 0.043	0.059 0.044	0.060 0.045	0.065 0.049	0.069 0.052	— 0.035
6	<i>Two Long Edges Discontinuous:</i> Negative moment at continuous edge Positive moment at mid-span	— 0.035	— 0.043	— 0.051	— 0.057	— 0.063	— 0.068	— 0.080	— 0.088	0.045 0.035
7	<i>Three Edges Discontinuous (One Long Edge Continuous):</i> Negative moment at continuous edge Positive moment at mid-span	0.057 0.043	0.064 0.048	0.071 0.053	0.076 0.057	0.080 0.060	0.084 0.064	0.091 0.069	0.097 0.073	— 0.043
8	<i>Three Edges Discontinuous (One Short Edge Continuous):</i> Negative moment at continuous edge Positive moment at mid-span	— 0.043	— 0.051	— 0.059	— 0.065	— 0.071	— 0.076	— 0.087	— 0.096	0.057 0.043
9	<i>Four Edges Discontinuous:</i> Positive moment at mid-span	0.056	0.064	0.072	0.079	0.085	0.089	0.100	0.107	0.056

moments per unit width are given by the following equation:

$$M_x = \alpha_x w l_x^2$$

$$M_y = \alpha_y w l_y^2$$

where M_x, M_y, w, l_x, l_y are same as those in D-1.1.

and α_x and α_y are moment coefficients given in Table 27

D-2.1.1 At least 50 percent of the tension reinforcement provided at mid-span should extend to the supports. The remaining 50 percent should extend to within 0.1 l_x or 0.1 l_y of the support, as appropriate.

Table 27 Bending Moment Coefficients for Slabs Spanning in Two Directions at Right Angles, Simply Supported on Four Sides
(Clause D-2.1)

l_y/l_x	1.0	1.1	1.2	1.3	1.4	1.5	1.75	2.0	2.5	3.0
α_x	0.062	0.074	0.084	0.093	0.099	0.104	0.113	0.118	0.122	0.124
α_y	0.062	0.061	0.059	0.055	0.051	0.046	0.037	0.029	0.020	0.014

Problem 1:

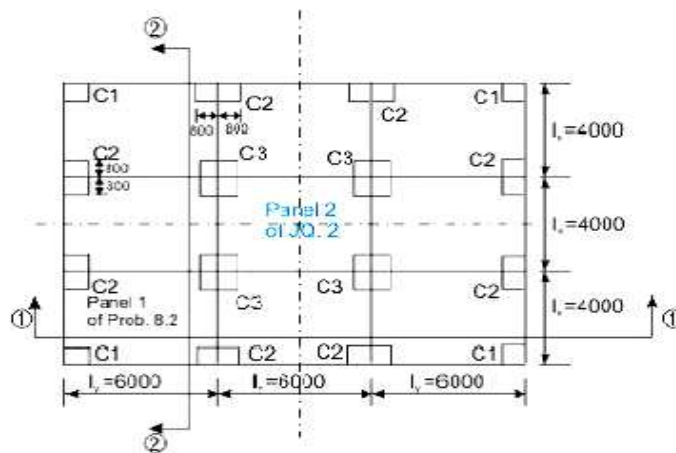

Fig. 8.19.7: Problem 8.2 (panel 1) and TQ 2 (panel 2)

Step 1: Selection of preliminary depth of slab

The span to depth ratio with Fe 415 is taken from cl. 24.1, Note 2 of IS 456 as $0.8(35 + 40) / 2 = 30$. This gives the minimum effective depth $d = 4000/30 = 133.33$ mm, say 135 mm. The total depth D is thus 160 mm.

Step 2: Design loads, bending moments and shear forces

Dead load of slab (1 m width) = $0.16(25) = 4.0$ kN/m²

Dead load of floor finish (given) = 1.0 kN/m²

Factored dead load = $1.5(5) = 7.5$ kN/m²

Factored live load (given) = 8.0 kN/m²

Total factored load = 15.5 kN/m²

The coefficients of bending moments and the bending moments M_x and M_y per unit width (positive and negative) are determined as per cl. D-1.1 and Table 26 of IS 456 for the case 4, “Two adjacent edges discontinuous” and presented in Table 8.6. The l_y / l_x for this problem is $6/4 = 1.5$.

Table 8.6 Maximum bending moments of Problem 8.2

For	Short span			Long span
	α_x	M_x (kNm/m)	α_y	M_y (kNm/m)
Negative moment at continuous edge	0.075	18.6	0.047	11.66
Positive moment at mid-span	0.056	13.89	0.035	8.68

Maximum shear force in either direction is determined from Eq.8.1 (Fig.8.19.1) as

$$V_u = w_u(l/2) = 15.5(4/2) = 31 \text{ kN/m}$$

Step 3: Determination/checking of the effective depth and total depth of slab

Using the higher value of the maximum bending moments in x and y directions from Table 8.6, we get from Eq.3.25 of Lesson 5 (sec. 3.5.5):

$$M_{u,lim} = Q_{lim} b d^2$$

$$\text{or } d = [(18.6)(10^6) / \{2.76(10^3)\}]^{1/2} = 82.09 \text{ mm,}$$

where 2.76 N/mm² is the value of Q_{lim} . Since, this effective depth is less than 135 mm assumed in Step 1, we retain $d = 135$ mm and $D = 160$ mm.

Step 4: Depth of slab for shear force

Table 19 of IS 456 gives the value of $\tau_c = 0.28$ N/mm² when the lowest percentage of steel is provided in the slab. However, this value needs to be modified by multiplying with k of cl. 40.2.1.1 of IS 456. The value of k for the total depth of slab as 160 mm is 1.28. So, the value of τ_c is $1.28(0.28) = 0.3584$ N/mm².

Table 20 of IS 456 gives $\tau_{cmax} = 2.8$ N/mm². The computed shear stress $\tau_v = V_u / b d = 31 / 135 = 0.229$ N/mm².

Since, $\tau_v < \tau_c < \tau_{cmax}$, the effective depth of the slab as 135 mm and the total depth as 160 mm are safe.

Step 5: Determination of areas of steel

The respective areas of steel in middle and edge strips are to be determined. It has been shown that the areas of steel computed from Eq.3.23 and those obtained from the tables of SP-16 are in good agreement. Accordingly, the areas of steel for this problem are computed from the respective Tables 40 and 41 of SP-16 and presented in Table 8.7. Table 40 of SP-16 is for the effective depth of 150 mm, while Table 41 of SP-16 is for the effective depth of 175 mm. The following results are, therefore, interpolated values obtained from the two tables of SP-16.

Table 8.7 Reinforcing bars of Problem 8.2

Particulars	Short span l_x				Long span l_y	
	Table No.	M_x (kNm/m)	Dia. & spacing	Table No.	M_y (kNm/m)	Dia. & spacing
Top steel for negative moment	40,41	18.68 > 18.6	10 mm @ 200 mm c/c	40,41	12.314 > 11.66	8 mm @ 200 mm c/c
Bottom steel for positive moment	40,41	14.388 > 13.89	8 mm @ 170 mm c/c	40,41	9.20 > 8.68	8 mm @ 250 mm c/c

The minimum steel is determined from the stipulation of cl. 26.5.2.1 of IS 456 and is

$A_s = (0.12/100)(1000)(160) = 192 \text{ mm}^2$ and 8 mm bars @ 250 mm c/c (= 201 mm²) is acceptable. It is worth mentioning that the areas of steel as shown in Table 8.7 are more than the minimum amount of steel.

Step 6: Selection of diameters and spacing of reinforcing bars

The advantages of using the tables of SP-16 are that the obtained values satisfy the requirements of diameters of bars and spacing. However, they are checked as ready reference here. Needless to mention that this steel may be omitted in such a situation.

Maximum diameter allowed, as given in cl. 26.5.2.2 of IS 456, is $160/8 = 20$ mm, which is more than the diameters used here.

The maximum spacing of main bars, as given in cl. 26.3.3(1) of IS 456, is the lesser of 3(135) and 300 mm. This is also satisfied for all the bars.

Step 7: Determination of torsional reinforcement

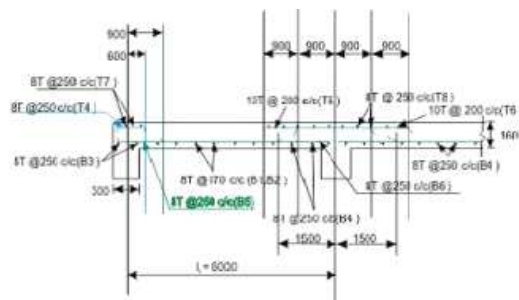

Fig. 8.19.8: Problem 8.2, Sec 1-1 of Panel 1 of Fig. 8.19.7

Torsional reinforcing bars are determined for the three different types of corners as explained in sec. 8.19.6 (Fig.8.19.4). The length of torsional strip is $4000/5 = 800$ mm and the bars are to be provided in four layers. Each layer will have 0.75 times the steel used for the maximum positive moment. The C1 type of corners will have the full amount of torsional steel while C2 type of corners will have half of the amount provided in C1 type. The C3 type of corners do not need any torsional steel. The results are presented in Table 8.8 and Figs.8.19.10 a, b and c.

Table 8.8 Torsional reinforcement bars of Problem 8.2

Type	Dimensions along		Bar diameter & spacing	No. of bars along	Cl. no. of IS 456	
	x (mm)	y (mm)			x	y
C1	800	800	8 mm @ 200 mm c/c	5	5	D-1.8
C2	800	1600	8 mm @ 250 mm c/c	5	8	D-1.9
C2	1600	800	8 mm @ 250 mm c/c	8	5	D-1.9

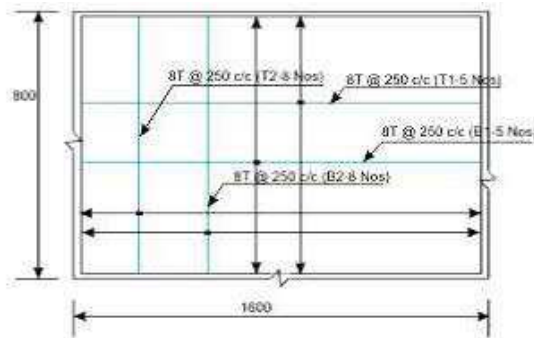

Fig. 8.19.10(c): Corners C2

Fig. 8.19.10: Torsion reinforcement bars of Problem 8.2

Problem No 2

A drawing room of a residential building measures 4.3 m × 6.55 m. It is supported on 350 mm thick walls on all four sides. The slab is simply supported at edges with no provision to resist torsion at corners. Design the slab using grade M 20 concrete and HYSD reinforcement of grade Fe 415.

Solution:

Consider 1 m wide strip. Assume 180 mm thick slab, with 160 mm effective depth.

$$l_x = 4.3 + 0.16 = 4.46 \text{ say } 4.5 \text{ m.}$$

$$l_y = 6.55 + 0.16 = 6.71 \text{ say } 6.75 \text{ m.}$$

$$\text{Dead load: self } 0.18 \times 25 = 4.5 \text{ kN/m}^2$$

$$\text{floor finish} = 1.0 \text{ kN/m}^2$$

$$\text{Live load (residence)} = 2.0 \text{ kN/m}^2$$

$$\text{Total } 7.5 \text{ kN/m}^2$$

For 1 m wide strip

$$P_u = 1.5 \times 7.5 = 11.25 \text{ kN/m.}$$

$$\frac{l_y}{l_x} = \frac{6.75}{4.5} = 1.5$$

$$M_{ux} = 0.104 \times 11.25 \times 4.5^2 = 23.7 \text{ kNm}$$

$$M_{uy} = 0.046 \times 11.25 \times 4.5^2 = 10.48 \text{ kNm}$$

$$d_{\text{required}} = \sqrt{\frac{23.7 \times 10^6}{1000 \times 2.76}} = 92.7 \text{ mm}$$

$$d_{\text{short}} = 180 - 15 \text{ (cover)} - 5$$

$$= 160 \text{ mm} > 92.7 \text{ mm} \dots\dots\dots (\text{O.K.})$$

$$d_{\text{long}} = 160 - 10 = 150 \text{ mm}$$

Larger depth is provided to satisfy deflection check.

$$\frac{M_u}{b d^2} \text{ (short)} = \frac{23.7 \times 10^6}{1000 \times 160 \times 160} = 0.926$$

$$p_t = 0.273$$

$$A_{st} \text{ (short)} = \frac{0.273 \times 1000 \times 160}{100} = 437 \text{ mm}^2.$$

$$\frac{M_u}{bd^2} \text{ (long)} = \frac{10.48 \times 10^6}{1000 \times 150 \times 150} = 0.466$$

$$p_t = 0.129$$

$$A_{st} = \frac{0.129 \times 1000 \times 150}{100} = 194 \text{ mm}^2.$$

$$\text{Minimum steel} = \frac{0.12}{100} \times 1000 \times 180 = 216 \text{ mm}^2.$$

Provide 10 mm ϕ about 180 mm c/c = 436 mm² in short span and 8 mm ϕ about 230 mm c/c = 217 mm² in long span.

The bars cannot be bent or curtailed because if 50% of long span bars are curtailed, the remaining bars will be less than minimum.

At top on support, provide 50% of bars of respective span to take into account any possible negative moment created due to monolithic nature of slab.

Check for development length:

$$\text{Long span } V_u = 11.25 \times 2.25 = 25.31 \text{ kN.}$$

$$M_{u1} = 0.87 \times 415 \times 217 \left(150 - \frac{415 \times 217}{1000 \times 20} \right) \times 10^{-6}$$

$$= 11.40 \text{ kNm.}$$

$$\text{Assuming } L_0 = 8 \phi$$

$$1.3 \times \frac{11.40 \times 10^6}{25.31 \times 10^3} + 8 \phi \geq 47 \phi$$

which gives $\phi \leq 15.01 \text{ mm} \dots\dots\dots (\text{O.K.})$

$$\text{short span } V_u = 11.25 \times 2.25 = 25.31 \text{ kN.}$$

$$M_{u1} = 0.87 \times 415 \times 436 \left(160 - \frac{415 \times 436}{1000 \times 20} \right) \times 10^{-6}$$

$$= 23.76 \text{ kNm.}$$

$$\text{Assuming } L_0 = 8 \phi$$

$$1.3 \times \frac{23.76 \times 10^6}{25.31 \times 10^3} + 8 \phi \geq 47 \phi$$

which gives $\phi \leq 31.3 \text{ mm} \dots\dots\dots (\text{O.K.})$

Note that the bond is usually critical along long direction.

Check for shear:

This is critical along long span

$$\text{Shear stress } \tau_v = \frac{25.31 \times 10^3}{1000 \times 150} = 0.169 \text{ N/mm}^2$$

$$\frac{100 A_s}{bd} = \frac{100 \times 217}{1000 \times 150} = 0.145$$

$$\tau_c = 0.28 \text{ N/mm}^2$$

$$k \tau_c = 0.28 \times 1.2 = 0.336 \text{ N/mm}^2 \dots\dots\dots (\text{O.K.})$$

Check for deflection:

The deflection shall be checked along short span.

$$\text{Basic } \frac{\text{span}}{d} \text{ ratio} = 20$$

$$\frac{100 A_s}{b d} = \frac{448 \times 100}{1000 \times 160} = 0.28.$$

$$\text{service stress} = 0.58 \times 415 \times \frac{435}{448} = 234 \text{ N/mm}^2$$

Note that $A_{st,req}$ is used here.

$$\text{Modification factor} = 1.5$$

$$\text{Permissible } \frac{\text{span}}{d} \text{ ratio} = 20 \times 1.5 = 30$$

$$\text{actual } \frac{\text{span}}{d} \text{ ratio} = \frac{4480}{160} = 28 \dots\dots\dots (\text{O.K.})$$

Check for cracking:

Maximum spacing permitted for short span steel

$$= 3 \times 160 = 480 \text{ or } 300 \text{ mm, i.e., } 300 \text{ mm}$$

Spacing provided = 180 mm $\dots\dots\dots (\text{O.K.})$

Maximum spacing permitted for long span steel = $3 \times 150 = 450 \text{ mm.}$

Spacing provided = 230 mm $\dots\dots\dots (\text{O.K.})$

Sketch: The designed reinforcements of slab are shown in fig. 10-26.

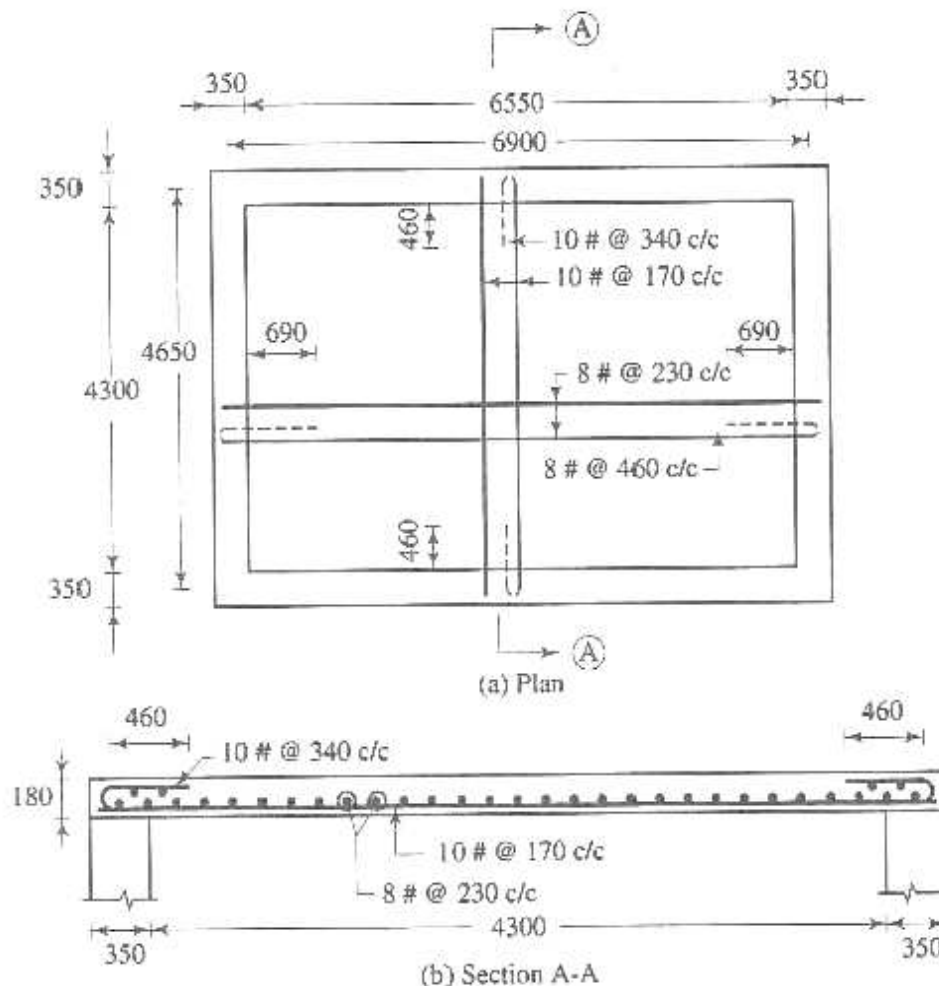

Note: It is possible to bend short span reinforcement alternately. Rework the problem

CHAPTER – 9

AXIALLY LOADED SHORT COLUMN

Introduction –

A column may be defined as an element used primarily to support axial compressive loads and with a height of at least three times its least lateral dimension. All columns are subjected to some moment which may be due to accidental eccentricity or due to end restraint imposed by monolithically placed beams or slabs. The strength of a column depends on the strength of the materials, shape and size of the cross-section, length and the degree of the positional and directional restraint at its end.

A column may be classified as short or long column depending on its effective slenderness ratio. The ratio of effective column length to least lateral dimension is referred to as effective slenderness ratio. A short column has a maximum slenderness ratio of 12. Its design is based on the strength of the materials and the applied loads. A long column has a slenderness ratio greater than 12. Its design is based on the strength of the materials and the applied loads. A long column has a slenderness ratio greater than 12. However, maximum slenderness ratio of a column should not exceed 0. A long column is designed to resist the applied loads plus additional bending moments induced due to its tendency to buckle.

ASSUMPTIONS -

The following assumptions are made for the limit state of collapse in compression.

1. Plane sections normal to the axis remain plane after bending.
2. The relationship between stress-strain distribution in concrete is assumed to be parabolic. The maximum compressive stress is equal to $0.67 \bar{\sigma}_{ck} / 1.5$ or $0.446 \bar{\sigma}_{ck}$.
3. The tensile strength of concrete is ignored.
4. The stresses in reinforcement are derived from the representative stress-strain curve for the type of steel used.
5. The maximum compressive strain in concrete in axial compression is taken as 0.002.
6. The maximum compression strain at the highly compressed extreme fibre in concrete subjected to axial compression and bending, but when there is no tension on the section, is taken as 0.0035 minus 0.75 times the strain at the least compressed extreme fibre.
7. The maximum compressive strain at the highly compressed extreme fibre in concrete subjected to axial compression and bending, when part of the section is in tension, is taken as 0.0035. In the limiting case when the neutral axis lies along one edge of the section, the strain varies from 0.0035 at the highly compressed edge to zero at the opposite edge.

The types of failures to the columns –

Columns, when centrally loaded, fail in one of the three following modes, depending on the slenderness ratio.

Fig.

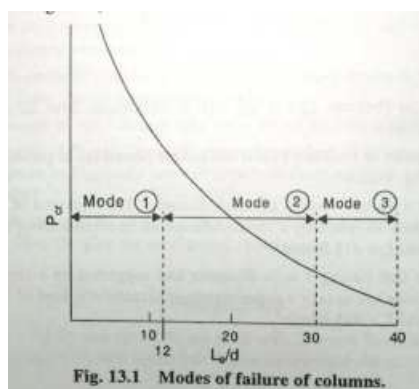

Mode :1 Pure compression failure

_____ The columns fail under axial loads without undergoing any lateral deformation. Steel and concrete reach the yield stress values at failure. The collapse is due to material failure.

Mode :2 Combined compression and bending failure

Short columns can be subjected to direct load (P) and moment (M). Slender columns even when loaded axially undergo deflection along their length as beam columns, and these deflections produce additional moments in the columns. When material failure is reached under the combined action of these direct loads and bending moment. It is called combined compression and bending failure.

Mode : 3 Failure by elastic instability

Very long columns can become unstable even under small loads well before the material reaches yield stresses. Under such cases the member fails by lateral 'elastic buckling'.

Failure by third mode is unacceptable in practical construction. R.C.C members that may fail by this type of failure is prevented by the code provision that columns beyond a specified slenderness should not be allowed in structure.

Braced and unbraced columns :

The columns in a building are classified as braced or unbraced according to the method applied to provide the lateral stability of the building.

- (1) **Braced column** : In braced frames, the lateral loads like wind, earthquake etc. are resisted by some special arrangements like shear walls, bracings or special supports. In other words, the sideways or joint translation is not possible in such columns. Sideways or joint translation means that one or both the ends of a column can move laterally with respect to each other. The columns occurring in braced buildings are called braced columns.

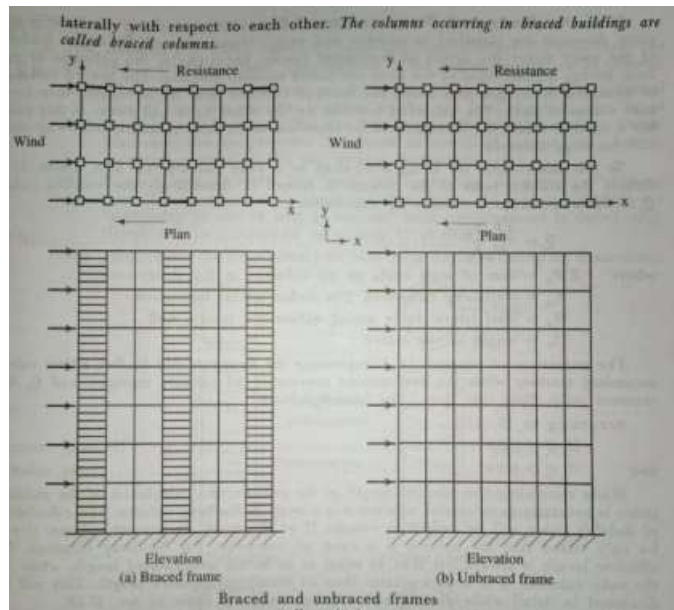

(2) **Unbraced columns :** A unbraced frames no special bracing systems are provided to resist horizontal forces. In other words the sidesway or joint translation do occur in such columns. The columns shall have to be designed to resist the lateral loads. The column those occur in the buildings where the resistance to lateral loads is provided by the bending in the columns and beams in that plane are called unbraced columns.

Effective length of columns :

The unsupported length or height_ of a column (L_0) is generally taken as the clear height of the columns. It is defined in IS 456, clause 25.1.3 for various cases of constructions. The effective length of column is different from unsupported length. Effective length (L_e) is dependent on the bracing and end conditions. It should be noted that for braced columns the effective column height is less than the clear height between restraints , whereas for unbraced and partially braced columns the effective height is greater than the clear height.

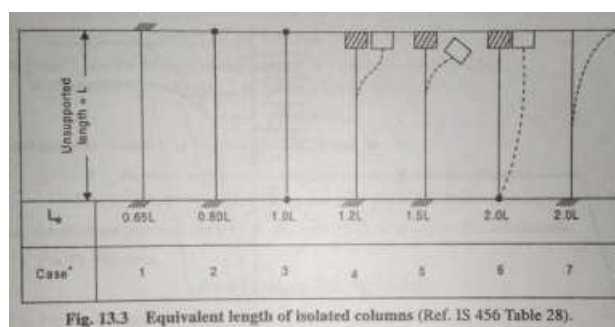

Design formula for Short column –

A rectangular column section bearing pure axial load. The design stress in mild steel at strain of 0.002 is $0.87 f_y$, however for , HYSD bars it is not so. The stresses corresponding to 0.002 strain in HYSD bars are as follows.

$$\begin{array}{ll} F_e 415 & 0.79 f_y \\ F_e 500 & 0.75 f_y \end{array}$$

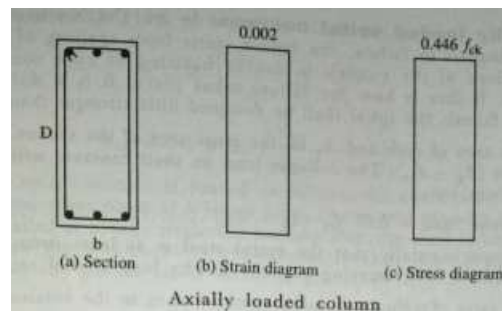

The code adopts the critical value of $0.75 f_y$ for all grades of steel for finding out the pure axial load carrying capacity of the column. Accordingly

$$P_{uz} = 0.446 f_{ck} A_c + 0.75 f_y A_{sc}$$

This is approximated as

$$P_{uz} = 0.446 f_{ck} A_c + 0.75 f_y A_{sc}$$

P_{uz} = Pure ultimate axial load carrying capacity of column.

f_{ck} = Characteristic compressive strength of concrete.

f_y = Characteristic strength of reinforcement.

A_c = Area of concrete in column section.

A_{sc} = Area of reinforcement in column section.

Axially loaded practical columns are subjected to moments due to minimum eccentricity . thus all the columns , even if the design load is axial, shall be designed for moments also.

The code simplifies the work for the columns in which minimum eccentricity $e_{min} \leq 0.05 D$. Thus , when $e_{min} \leq 0.05 D$, the above equation is modified as

$$P_u = 0.4 f_{ck} A_c + 0.67 f_y A_{sc} \dots \dots \dots$$

It can be seen that , the load carrying capacity of the column is reduced by about 10 percent when $e_{min} \leq 0.05 D$. however if $e_{min} \leq 0.05 D$, the column shall be designed for moment also.

The above equation can written as –

$$P_u = 0.4 f_{ck} \left(A_g - \frac{P A_g}{100} \right) + 0.67 f_y \frac{P A_g}{100}$$

Where A_g = Gross area of cross section

P = Percentage of reinforcement.

Dividing both sides by A_g

$$\frac{P_u}{A_g} = 0.4 f_{ck} \left(1 - \frac{P A_g}{100}\right) + 0.67 f_y \frac{P}{100}$$

$$= 0.4 f_{ck} \frac{P}{100} (0.67 f_y - 0.4 f_{ck}) \dots$$

The compression in steel f_s at failure ($\epsilon_c = 0.002$) will be

$f_s = 0.87 f_y$ for steel with bilinear stress-strain curve as in Fe 250 steel.

$= 0.75 f_y$ for steel with stress-strain curve as in Fe 415 steel.

Hence, the ultimate carrying capacity of the column p_u is given by the expression

1. For Fe 415 steel, $P = A_c (0.45 f_{ck}) + A_s (0.75 f_y - 0.45 f_{ck})$

2. For Fe 250 steel, $P = A_c (0.45 f_{ck}) + A_s (0.87 f_y - 0.45 f_{ck})$

However it is never possible to apply the load centrally on a column. Accidental eccentricities are bound to happen. Indian and British codes allow an accidental eccentricity of 5 percent of the lateral dimension of the column in the plane of bending ($0.05 D$) in the strength formula itself. For this purpose the ultimate load p_u for Fe 415 steel reduces to

$$P_u = 0.9 (0.45 f_{ck} A_c + 0.75 f_y A_s)$$

$$P_w = 0.4 f_{ck} A_c + 0.67 f_y A_s \quad \text{as given in IS 456, clause 38.3}$$

With Fe 250 steel the corresponding expression will be

$$P_u = 0.4 f_{ck} A_c + 0.75 f_y A_s$$

It should be clearly noted these formula already take into account a maximum accidental eccentricity of ($0.05 D$) or ($0.05b$) in these columns.

Check for Minimum Eccentricity

Minimum eccentricities are caused by imperfections in construction, inaccuracy in loading etc. The BS code 8110 (1985) Clause 3.8.2.4 assumes that its value will be equal to $0.05 D$, but not more than 20mm.

IS 456, Clause 25.4 gives an expression for the possible minimum eccentricity as $e_{min} = \frac{L_0}{500} + \frac{D}{30}$ but not less than 20mm.

Where L_0 = the unsupported length

D = lateral dimensions in the plane of bending.

For sections other than rectangular, the Explanatory handbook SP 24 recommends a value of $L_e / 300$, where L_e is the effective length of the column.

Thus for example, for a column 600×450 of unsupported height 3 m, considering the long direction according to IS formula,

$$e_{min} = \frac{L_0}{500} + \frac{D}{30} = \frac{3000}{500} + \frac{600}{30} = 26\text{mm.}$$

As 26mm is greater than the minimum specified 20mm, use $e_{min} = 26\text{mm}$. then $\frac{e_{min}}{D} = \frac{26}{600} = 0.043$

Considering the short direction, we have

$$e_{min} = 3000/500 + 450/30 = 21\text{mm} > 20\text{mm}.$$

$$\text{Hence } \frac{e}{b} = \frac{21}{450} = 0.047.$$

Both these values are less than the specified ratio of 0.05, and hence the simple column formula is applicable to the above column. If the eccentricities are more, then the column has to be designed as subjected to direct load P and moment Pe.

Minimum Longitudinal and Transverse reinforcement –

The reinforcement requirements are set out in clause 26.5.3 of IS 456.

1. Longitudinal Reinforcement:

- (i) The cross sectional area of longitudinal reinforcement shall be not less than 0.8 percent of gross cross sectional area of the column.

The minimum area of the reinforcement is specified to avoid the sudden non-ductile failure of the column, to resist creep and shrinkage and to provide some bending strength to the column.

- (ii) In any column that has a larger cross sectional area than that required to support the load, the minimum percentage of steel should be based upon the area of concrete required to resist the direct stress and not upon the actual area.

Because of the architectural or the other reasons, sometimes the columns are made larger in section than that required to resist the load. In such a case, according to this criteria, the minimum percentage of steel is based on concrete area required to resist the direct load. A concrete pedestal used to transfer the load from steel stanchion to the foundation in an industrial building is a typical example for this case. In this case, the size of the pedestal is governed by the size of the base plate under the steel column.

- (iii) The cross sectional area of longitudinal reinforcement shall be not more than 6 percent of the gross cross sectional area of the column.

The use of 6percent reinforcement may involve practical difficulties in placing and compacting of concrete, hence lower percentage is recommended where bars from the columns below have to be lapped with those in the column under consideration, the percentage of steel usually should not exceed 4 percent. for the column with more than 4 percent steel, the laps may be staggered.

- (iv) The minimum number of longitudinal bars provided in a column shall be four in rectangular columns and six in circular columns.

- (v) The bar shall not be less than 12 mm in diameter.

- (vi) A reinforced concrete column having helical reinforcement shall have at least six bars of longitudinal reinforcement within the helical reinforcement.

- (vii) In a helical reinforced column, the longitudinal bars shall be in contact with the helical reinforcement and equidistant around its inner circumference.
- (viii) Spacing of longitudinal bars measured along the periphery of the column shall not exceed 300 mm. this is a cracking requirement.
- (ix) In case of the pedestals in which the longitudinal reinforcement is not taken into account in strength calculation, nominal reinforcement not less than 0.15 percent of the cross sectional area shall be provided.

(2) Transverse Reinforcement:

- (i) General : a reinforcement concrete compression member shall have transverse or helical reinforcement so disposed that every longitudinal bar nearest to the compression face has effective lateral support against bulking subject to provisions in (b). The effective lateral support is given by transverse reinforcement either in the form of circular rings capable of taking up circumferential tension or by polygonal links (lateral ties) with internal angles not exceeding 135 degree. The ends of the transverse reinforcement shall be properly anchored.
- (ii) Arrangement of transverse reinforcement :
 - (a) If the longitudinal bars are not spaced more than 75mm on either side, transverse reinforcement need only to go round the corner and alternate bars for the purpose of providing effective lateral supports.
 - (b) If the longitudinal bars spaced at a distance of not exceeding 48 times the diameter of the tie are effectively tied in two directions, additional longitudinal bars in between these bars need to be tied in one direction by open ties.
 - (c) Where the longitudinal reinforcing bars in a compression member are placed in more than one row, effective lateral support to the longitudinal bars in the inner rows may be assumed to have been provided if-
 - (1) Transverse reinforcement is provided for outer most row in accordance with (b) and
 - (2) No bar of the inner row is closer to the nearest compression face than three times the diameter of the largest bar in the inner row.
 - (d) Where the longitudinal bars in a compression member are grouped and each group adequately tied transverse reinforcement in accordance with the above requirements, the transverse reinforcement for the compression member as a whole may be provided on the assumption that each group is a single longitudinal bar for purpose of determining the pitch and diameter of the transverse reinforcement in accordance with above requirements. The diameter of such transverse reinforcement need not, however exceed 20mm.
- (iii) Pitch and diameter of lateral tie :

- (a) Pitch : the pitch of transverse reinforcement shall be not more than the least of the following distances:
- (1) The least lateral dimension of the compression member.
 - (2) Sixteen times the smallest diameter of the longitudinal reinforcement bar to be tied.
 - (3) 300mm.
- (b) Diameter : the diameter of the polygonal links or ties shall be not less than one fourth of the diameter of the largest longitudinal bar and in no case less than 6 mm.
- (iv) Helical reinforcement :
- (a) Pitch : Helical reinforcement shall be of regular formation with the turns of the helix spaced evenly and its ends shall be anchored properly by providing one and a half extra turns of the spiral bar. Where an increase load on the column on the strength of the helical reinforcement is allowed for, the pitch of helical turns shall be not more than 75 mm, nor more than one-sixth of the core diameter of the column, nor less than 25mm, nor less than there times the diameter of the steel bar forming the helix.
 - (b) Diameter : the diameter of the helical reinforcement shall be as per lateral ties.
- (v) Cover : the longitudinal reinforcing bar in a column shall have concrete cover, not less than 40mm, nor less than the diameter of such bar. This requirements gives a fire protection of 0.5 h to 4h (h = hour) and is suitable for moderate exposure assuming a maximum of 10 mm diameter tie. However the cover to the ties may be governed by exposure conditions. In the case of columns the minimum dimensions of 200 mm or under, whose reinforcing bars do not exceed 12mm, a cover of 25mm may be used.

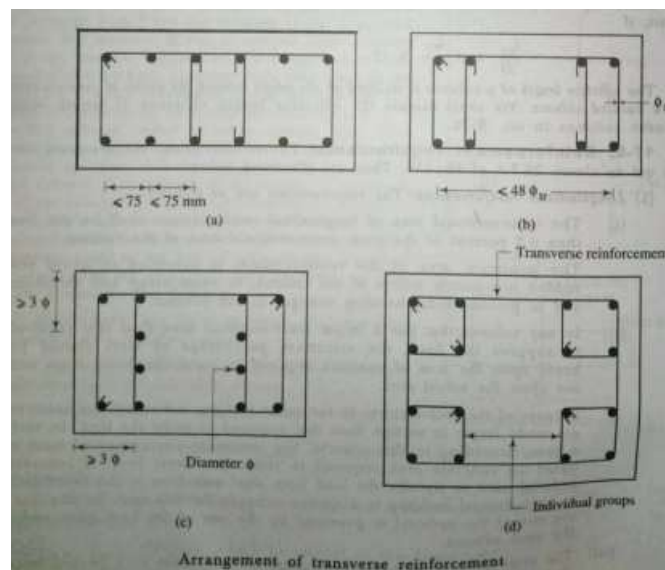

Design of short column by IS 456 and SP 16 –

Charts 24 to 26 of the IS publication design aids SP 16 can be used for routine office design of short columns. These charts are made from the column formula

$$P_u = 0.4 f_{ck} A_c + 0.67 f_y A_{sc}$$

A_g = area of cross section

$$P = \text{percentage of steel} = 100 \frac{A_s}{A_g}$$

The area of steel and concrete are given by

$$A_s = \frac{P A_g}{100}$$

$$A_c = A_g - A_s = A_g \left(1 - \frac{P}{100}\right)$$

Rewriting the equation with above quantities, we obtain

$$\frac{P_u}{A_g} = 0.4 f_{ck} \left(1 - \frac{P}{100}\right) + 0.67 f_y \frac{P}{100}$$

$$P_u = \left[0.4 f_{ck} \frac{P}{100} + 0.67 f_y - 0.4 f_{ck} \frac{P}{100} \right] A_g$$

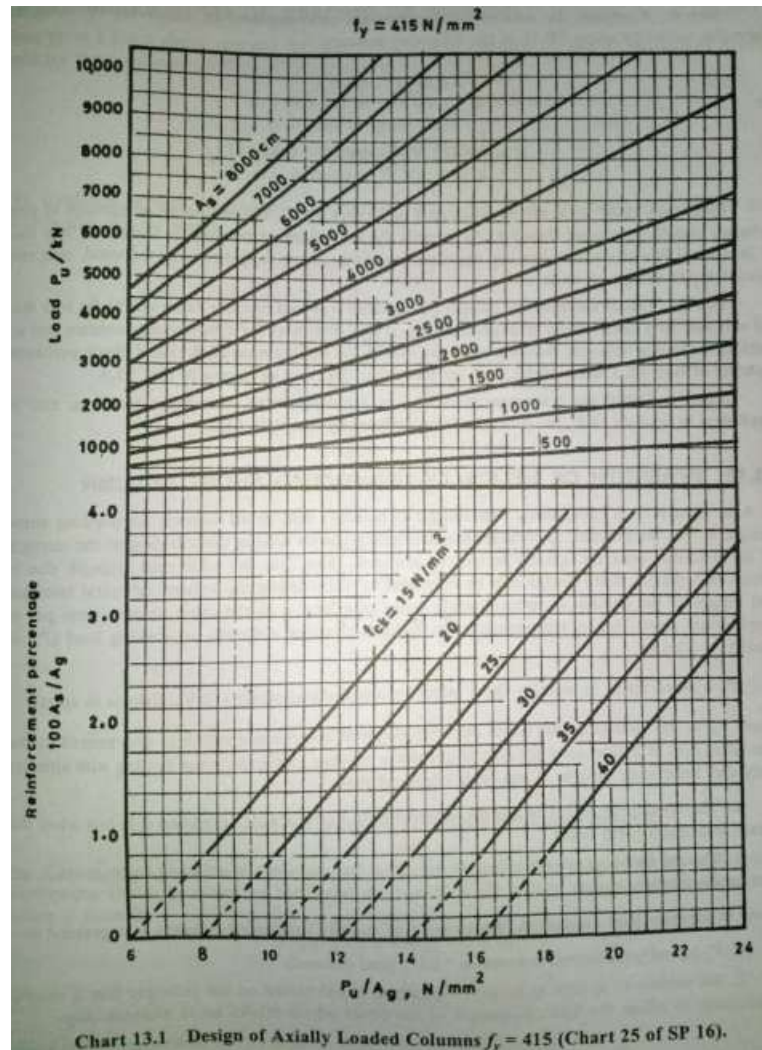

Chart 24 to 26 of SP 16 have been prepared from these formula for Fe 250 , Fe 415 and Fe 500 and $f_{ck} = 15, 20, 30, 35, \text{ and } 40$.

To use design chart , choose the value of the factored design load P_u , and proceed horizontally till the A_g corresponding to the size of the column selected is reached. The value of percentage of steel required for the adopted value of f_{ck} is read off from the lower half of chart 13.1.

Procedure for design of centrally loaded short column:

The step-by-step procedure for design of a centrally loaded column can be arranged as follows:

Step 1 : compute the factored load on the column.

Step 2 : Choose a suitable size for the column, depending on the size of the beam that has to be placed on it and the architectural requirements. Usually the beams are accommodated inside the column. Check also the minimum eccentricity.

Step 3: Determine the effective length length and slenderness of the column about the principal axes. If it is less than 12, it can be considered as a short column. If it is 12 or more, it is to be designed as a long column.

Step 4 : compute the area of the longitudinal steel required by either (a) by using the formula or (b) by using SP 16 in the following manner.

$$P_u = 0.4 f_{ck} A_c + 0.67 f_y A_{sc}$$

or
$$P_u = [0.4 f_{ck} \frac{P}{100} (0.67 f_y - 0.4 f_{ck}) A_g$$

The minimum percentage of steel adopted should be greater than 0.8. As regards the maximum percentage , it should be less than 4 in normal designs where lapping becomes essentials. Where lapping is not adopted, one may accept a percentage of up to 6.

Step 5: Detail the steel by choosing a suitable size and number (size not to be less than 12mm and for a symmetrical arrangement with at least four bars for a rectangular column and six bars for a circular column). Adopt a suitable cover to the steel (clause 26.4.1) and check perimeter spacing of bars (IS clause 26.5.3.1) is not more than 300mm.

Step 6: Detail the transverse steel. Adopt a suitable size, determine spacings, etc.

Strength of helically reinforced short column:

IS 456, clause 26.5.3.2(d) deals with design of helically reinforced column. In working stress design, it was practice to consider the strength of spirals also in contributing to the strength of the column. Tests on spirally reinforced reinforced columns show that the additional strength due to spirals in working stress design can be estimated by considering the volume of spiral steel per unit height of the column is approximately twice as effective as the same volume were put as longitudinal steel. Hence the equation for strength of spiral columns in working load (P_c) is usually written as

$$P_c = (\text{Load taken by core}) + (\text{load taken by longitudinal steel}) + 2 (V_{sh}) (\text{stress in spiral})$$

Where V_{sh} is the volume of the spiral per unit length of the column which is also termed as the equivalent area of helical steel per unit height of the column. However when dealing with ultimate loads and limit state design, it has been observed that

1. The containing effect of spirals is useful only in the elastic stage and it is lost when the spirals also reach yield point.
2. The spirals become fully effective only after the concrete cover over the spirals spalls off after excessive deformation.

Hence in ultimate load estimation , the strength of spirally reinforced columns is expressed by

1. P_u (spirally reinforced column) = 1.05 P_u (tied column)
2. The volume of spirals to be provided which is calculated on the principle that it should be adequate to offset the loss of strength of the cover which cracks up at ultimate stage.

Calculation of spacing of spirals:

S = Pitch or spacing of spirals used.

a = area of spiral steel .

D = diameter of the column.

D_k = diameter of the core.

The condition is that the loss of strength due to spalling of cover should be equal to the contribution due to spirals.

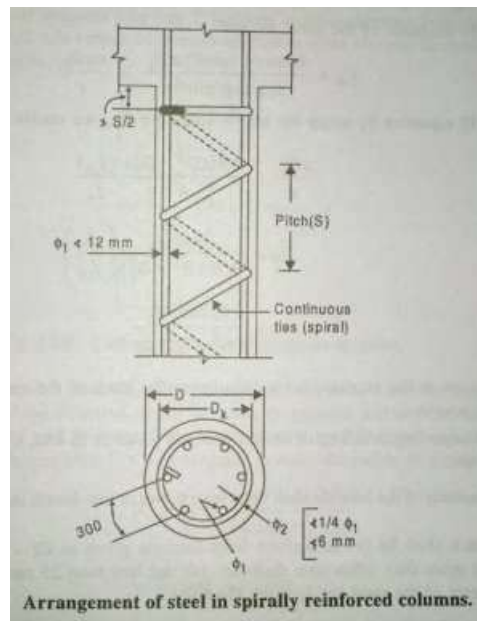

Taking A_k as the area of the core and A_g as the area of cross section and using the same assumption about the action of the spiral as is used in the elastic design, the relationship at failure is given by

$$2V_{sh}(0.87f_y) = 0.63 f_{ck} (A_g - A_k)$$

$$V_{sh} = 0.36 (A_g - A_k) \left(\frac{f_{ck}}{f_y} \right)$$

Which can be reduced to the form given in IS 456, clause 38.4.1 as

$$\frac{V_{sh}}{A_k} = 0.36 \left(\frac{A_g}{A_k} - 1 \right) \left(\frac{f_{ck}}{f_y} \right)$$

Where A_g = gross area of section

A_k = area of core.

This expression gives the ratio of the volume of the helical reinforcement required for the volume of the core per unit height of the column.

Simplifying this expression further, one can write

$$V_{sh} = (\text{Volume of the spiral in one ring}) \times (\text{No. Of rings per unit length})$$

Taking D_k as the diameter of the core , we get

$$V_{sh} = \frac{(\text{area of spiral}) \pi D_k}{\text{Spacing (pitch)}} = \frac{a \pi D_k}{s}$$

Rewriting the IS equation by using the above value for V_{sh} , we get

$$\frac{aD_k}{s} = \frac{0.36 (D^2 - D_k^2)}{4} \frac{f_{ck}}{f_y}$$

$$S = \frac{4aD_k}{0.36 (D^2 - D_k^2)} \frac{f_y}{f_{ck}}$$

$$S = \frac{11.1aD_k f_y}{f_{ck} (D^2 - D_k^2)} \dots\dots\dots(1)$$

Which can be used as the expression for calculating the pitch of the spirals for a given steel of cross section area a.

The rules regarding detailing of helical steel are given IS 456, clause 26.5.3.2. the main considerations are:

1. The diameter of the helicals shall be at least 6mm or one fourth the diameter of longitudinal steel.
2. The pitch shall be (a) as derived from formula equation (1) (b) not more than 75mm, (c) not more than 1/6th core diameter , (d) not less than 25mm, (e) not less than three times the diameter of the steel bar forming the helix.

If the diameter and the pitch of the spirals do not comply with the above rules, the strength is to be taken as only that of a tied column of similar dimension.

Problem 1:

A column of 400 x400mm has an unsupported length of 7m and effective length of 4.5 m. Can it be designed as a short column under axial compression , if the load placed centrally on it?

Solution:

Step 1: Slenderness ratio consideration

$$\frac{L_e}{D} = 4500 / 400 = 11.25 \quad (\text{IS456 Cl.25.1.2})$$

As columns with slenderness less than 12 can be considered as short , the column is short.

Step 2: Eccentricity considerations

$$e_{min} = \frac{L_0}{500} + \frac{D}{30} \text{ not less than 20mm. } (\text{IS 456 Cl . 25.4})$$

$$= 7000/ 500 + 400/30$$

$$= 14 + 13.3$$

27.3 mm is greater than 20mm. Adopt 27.3mm

The eccentricity for which short column formula is applicable is D/20

$$D/20 = 400/20 = 20\text{mm} \quad (\text{IS 456 Cl.39.3})$$

$$e_{min} > D/20$$

Hence formula for axial load is not applicable.

Column should be designed as subject to axial load and moment due to e_{min} .

$$(M = P e_{min})$$

Problem – 2

Design an axially loaded tied column 400 x 400 mm pinned at both ends with an unsupported length of 3m for carrying a factored load of 2300 KN. Use grade 20 concrete and Fe 415 steel.

Solution:

Step 1: Factored load on column

$$P_u = 2300\text{KN}$$

Step 2: Size of column and check e_{min} (IS 456 Cl. 25.4)

Size of column = 400 x 400, $D/20 = 20\text{mm}$

$$e_{min} = \frac{L_0}{500} + \frac{D}{30} = 3000/500 + 400/30 = 19.33 < 20\text{mm}$$

e_{min} less than $D/20$ is assumed in the formula. Hence short column formula for axial load can be used.

Step 3: Calculation of slenderness (IS456 Cl. 25.1.2)

$$L_e = 1.0L = 3000\text{mm}$$

$$\frac{L_e}{b} = 3000/400 = 7.5 < 12$$

Step 4: Find area of steel and check percentage

$$(a) \text{ By formula, } P_u = 0.4 f_{ck} A_c + 0.67 f_y A_{sc} \quad (\text{IS 456 Cl. 39.3})$$

$$2300 \times 10^3 = 0.4 \times 20 \times (400^2 - A_s) + 0.67 \times 415 \times A_s$$

$$A_s = 3777 \text{ mm}^2, P = 3777/400^2 \times 100 = 2.36\%$$

This is more than 0.8% and less than 6%. hence o. k

$$(b) \text{ By SP 16, } A_g = 1600 \text{ cm}^2, P = 2300 \text{ KN. } P = 2.4\% \quad (\text{SP 16 chart 25})$$

$$A_s = (2.4 \times 400 \times 400) / 100 = 3840 \text{ mm}^2 \quad (\text{Use 8T -25 / 3927 mm}^2)$$

Step 5 : Detail the longitudinal steel

$$\text{Use cover} = 40\text{mm} \quad (\text{Cl. 26.4.2.1})$$

$$\text{Steel spacing} = (400 - 40 - 40 - 25) / 2 = 147.5$$

$$\text{Clear spacing between bars} = 147.5 - 25 = 122.5 < 300 \quad (\text{Cl.26.5.3.1 g})$$

Step 6: Design transverse steel

Diameter of links : not less than $25/4$ or 6mm.

Use 10mm

Spacing least of [Cl. 26.5.3.2 (c)]

(a) Dimension of column = 400mm

(b) 16 times \emptyset of long steel = $16 \times 25 = 400\text{mm}$

(c) 300 mm adopt 300mm.

Use Fe250 steel for ties.

$$(a) S = \frac{11.1 \alpha D_k f_y}{f_{ck} (D^2 - D_k^2)} = (11.1 \times 28 \times 400 \times 145) / (57600 \times 30)$$

$$= 30\text{mm} \quad \text{Cl. 39.4.1}$$

- (b) Spacing not more than 75mm
- (c) Spacing not more than $320 / 6 = 53.3\text{mm}$
- (d) Spacing not less than 25
- (e) Spacing not less than $6 \times 3 = 18\text{mm}$

Choose 30mm spacing.

(Design helically reinforced columns)

Problem 1 :

Design a circular pin ended column 400 mm dia and helically reinforced , with an unsupported length of 4.5 m to carry a factored load of 900 KN. Assume M30 concrete and Fe 415 steel.

Solution:

Step 1: Factored load, $P_u = 900\text{ Kn}$.

Step 2: Size of column $D = 400\text{mm}$, cover = 40mm

$$D_{core} = 320\text{mm}$$

$$D/20 = 400/20 = 20\text{mm}.$$

$$e_{min} = \frac{L_0}{500} + \frac{400}{30} = \frac{4500}{500} + \frac{400}{30} = 22.3\text{mm} > 20\text{mm}.$$

As $e_{min} > D/20$, theoretically short column formula for centrally loaded column is not applicable. However the column is designed as centrally loaded, as the moment to be considered is small.

Step 3: Slenderness of column

$$\frac{L_e}{D} = 4500/40 = 11.25 < 12. \quad (\text{centrally loaded Short Column})$$

Step 4: Area of longitudinal steel

$$P_u = 1.05 (0.4 f_{ck} A_c + 0.67 f_y A_s) \quad (\text{IS456 Cl. 39.4})$$

$$A_c = \pi \times 400^2 / 4 = 125.6 \times 10^3 \text{ mm}^2, \frac{P}{1.05} = \frac{900}{1.05} = 857 \text{ KN}.$$

$$\begin{aligned} 857 \times 10^3 &= [.4 \times 30 \times (125600 - A_s) + 0.67 \times 415 A_s] \\ &= 1507 \times 10^3 + A_s (278 - 12) \end{aligned}$$

Concrete itself can carry more than the required load.

Hence provide minimum steel.

$$A_{s(min)} = 0.8\% \text{ (of area required to carry P)} \quad \text{IS 456 Cl 26.5.3.1 (a) (b)}$$

$$A_c \text{ to resist given } P = \frac{900 \times 10^3}{1.05 \times 0.4 \times 30} = 71428\text{mm}^2$$

$$A_{s(min)} = \frac{0.8}{100} \times (71428) = 571.4 \text{ mm}^2.$$

Provide 6 nos. Of 12mm bars giving area 678 mm² as minimum number of bars allowed is 6 nos.

Step 5: Design Spirals CL.26.5.3.1(c)

Choose 6mm, $a = 28 \text{ mm}^2$ (area) , $s =$ pitch.

Detailing at junctions with reinforcement footing –

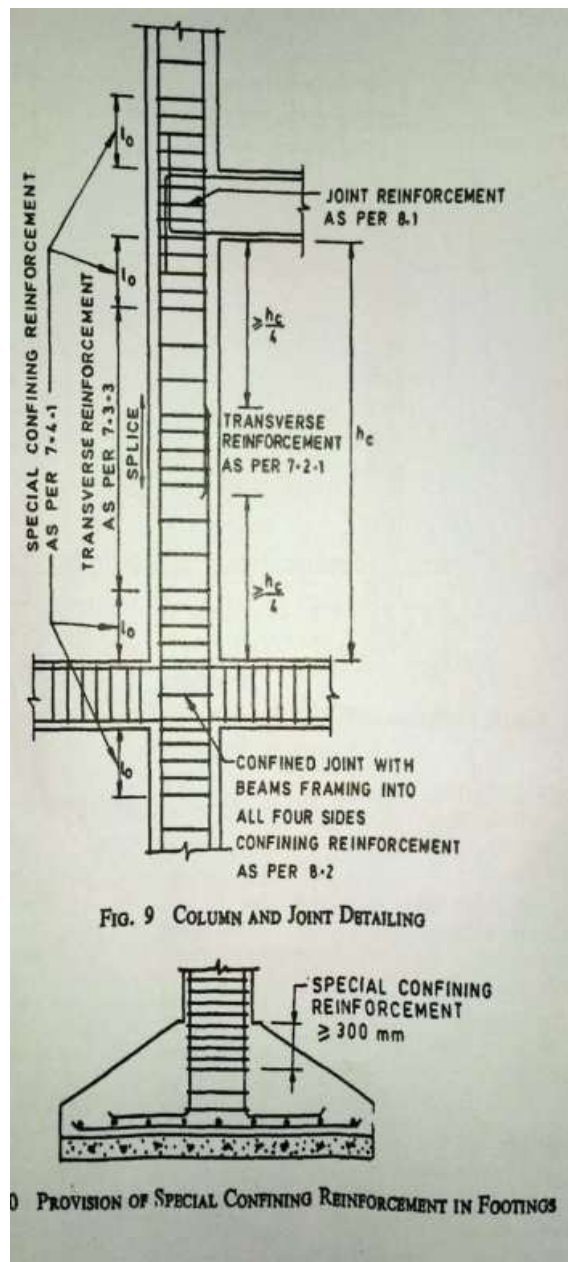

CHAPTER – 10

Ductility

Introduction –

Member or structural ductility is defined as the ratio of absolute maximum deformation to the corresponding yield deformation. However ductility has no precise meaning until the method of measuring the deformation has been defined. This can be defined with respect to strains, rotations, curvatures or deflections. Strain based ductility definition depends almost exclusively on the materials, while rotation or curvature based ductility definition also includes the effects of shape and size of the cross section. When the definition is applied to deflections, the entire configuration of structure and loading is also taken into account.

Necessity of ductility -

When a ductile structure subjected to overloading it will tend to deform in elastically and in doing so, will redistribute the excess load to elastic parts of the structure. This concept can be utilized in several ways.

1. If a structure is ductile, it can be expected to adapt to unexpected overloads, load reversals, impact and structural movements due to foundation settlements and volume changes. These items are generally ignored in the analysis and design but are assumed to have been taken care of by the presence of some ductility in the structure.
2. If a structure is ductile, its occupants will have sufficient warning of the impending failure thus reducing the probability of loss of life in the event of collapse.
3. The limit state design procedure assumes that all the critical sections in the structure will reach their maximum capacities at design load for the structure. For this to occur, all joints and splices must be able to withstand forces and deformations corresponding to yielding of the reinforcement.

Methods of improving ductility in R.C structure –

Selection of cross –section that will have adequate strength is rather easy. But it is much more difficult to achieve the desired strength as well as ductility. To ensure sufficient ductility , the designer should pat attention to detailing of reinforcement, bar cut-offs, splicing and joint details. Sufficient ductility can be ensured by following certain simple design details such as .

1. The structural layout should be simple and regular avoiding offsets of beams to columns. or offsets of columns from floor to floor. Changes in stiffness should be gradual from floor to floor.
2. The amount of tensile reinforcement in beams should be restricted and more compression reinforcement should be provided. The later should be enclosed by stirrups to prevent it from buckling.
3. Beams and columns in a reinforced concrete frame should be designed in such a manner that inelasticity is confined to beams only and the columns should remain elastic. To ensure this, sum of the moment capacities of the columns for the design axial loads at a beam column joint should be greater than the moment capacities of the beams along each principal plane.

$$\sum M_{column} > 1.2 \sum M_{beam}$$

4. The shear reinforcement should be adequate to ensure that the strength in shear exceeds the strength in flexure and thus, prevent a non-ductile shear failure before the fully reversible flexural strength of a member has been developed.

Clause 6.3.3 of IS : 13920 – 1993 requires that the shear resistance shall be the maximum of the :

- (a) Calculated factored shear forces as per analysis and
 - (b) Shear force due to formation of plastic hinges at both ends plus the factored gravity loads on the span.
5. Closed stirrups or spiral should be used to confine the concrete at sections of maximum moment to increase the ductility of members. Such sections includes upper and lower end of columns, and within beam- column joints which do not have beams on all sides. If axial load exceeds 0.4 times the balanced axial load, a spiral column is preferred.
 6. Splices and bar anchorages must be adequate to prevent bond failures.
 7. The reversal of stresses in beams and columns due to reversal of direction of earthquake force must be taken into account in the design by appropriate reinforcement.
 8. Beam-column connections should be made monolithic.

Detailing of beam as per I.A – 13920 Clause no . 6.1.6.2.6.3

5.2 For all buildings which are more than 3 storeys in height, the minimum grade of concrete shall preferably be M20 ($f_{ck} = 20$ MPa).

5.3 Steel reinforcements of grade Fe 415 (see IS 1786 : 1985) or less only shall be used.

6 FLEXURAL MEMBERS

6.1 General

These requirements apply to frame members resisting earthquake induced forces and designed to resist flexure. These members shall satisfy the following requirements.

6.1.1 The factored axial stress on the member under earthquake loading shall not exceed $0.1 f_{ck}$.

6.1.2 The member shall preferably have a width-to-depth ratio of more than 0.3.

6.1.3 The width of the member shall not be less than 200 mm.

6.1.4 The depth D of the member shall preferably be not more than $1/4$ of the clear span.

6.2 Longitudinal Reinforcement

6.2.1 a) The top as well as bottom reinforcement shall consist of at least two bars throughout the member length.

b) The tension steel ratio on any face, at any section, shall not be less than $p_{min} = 0.24 \sqrt{f_{ck}/f_y}$; where f_{ck} and f_y are in MPa.

6.2.2 The maximum steel ratio on any face at any section, shall not exceed $p_{max} = 0.025$.

6.2.3 The positive steel at a joint face must be at least equal to half the negative steel at that face.

6.2.4 The steel provided at each of the top and bottom face of the member at any section along its length shall be at least equal to one-fourth of the maximum negative moment steel provided at the face of either joint. It may be clarified that redistribution of moments permitted in IS 456 : 1978 (clause 36.1) will be used only for vertical load moments and not for lateral load moments.

6.2.5 In an external joint, both the top and the bottom bars of the beam shall be provided with anchorage length, beyond the inner face of the column, equal to the development length in tension plus 10 times the bar diameter minus the allowance for 90 degree bend(s) (see Fig. 1). In an internal joint, both face bars of the beam shall be taken continuously through the column.

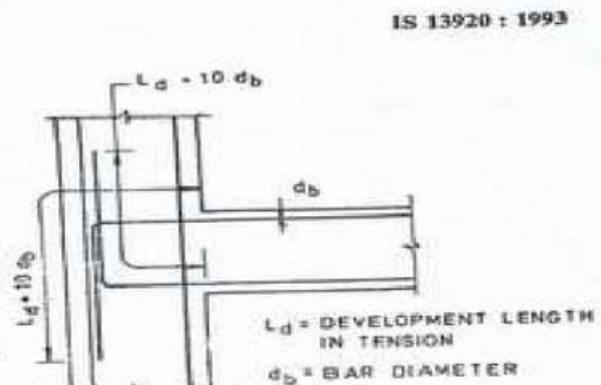

FIG. 1 ANCHORAGE OF BEAM BARS IN AN EXTERNAL JOINT

6.2.6 The longitudinal bars shall be spliced, only if hoops are provided over the entire splice length, at a spacing not exceeding 150 mm (see Fig. 2). The lap length shall not be less than the bar development length in tension. Lap splices shall not be provided (a) within a joint, (b) within a distance of $2d$ from joint face, and (c) within a quarter length of the member where flexural yielding may generally occur under the effect of earthquake forces. Not more than 50 percent of the bars shall be spliced at one section.

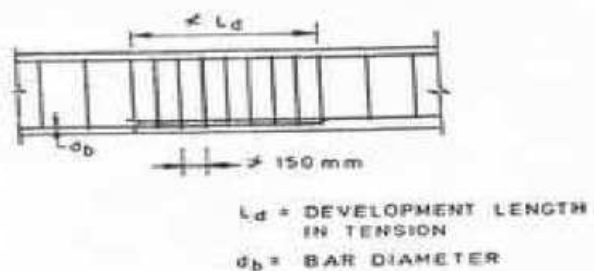

FIG. 2 LAP, SPLICE IN BEAM

6.2.7 Use of welded splices and mechanical connections may also be made, as per 25.2.5.2 of IS 456 : 1978. However, not more than half the reinforcement shall be spliced at a section where flexural yielding may take place. The location of splices shall be governed by 6.2.6.

IS 13920 : 1993

6.3 Web Reinforcement

6.3.1 Web reinforcement shall consist of vertical hoops. A vertical hoop is a closed stirrup having a 135° hook with a 10 diameter extension (but not < 75 mm) at each end that is embedded in the confined core (see Fig. 3a). In compelling circumstances, it may also be made up of two pieces of reinforcement; a U-stirrup with a 135° hook and a 10 diameter extension (but not < 75 mm) at each end, embedded in the confined core and a crosstie (see Fig. 3b). A crosstie is a bar having a 135° hook with a 10 diameter extension (but not < 75 mm) at each end. The hooks shall engage peripheral longitudinal bars.

6.3.2 The minimum diameter of the bar forming a hoop shall be 6 mm. However, in beams with clear span exceeding 5 m, the minimum bar diameter shall be 8 mm.

6.3.3 The shear force to be resisted by the vertical hoops shall be the maximum of:

- calculated factored shear force as per analysis, and
- shear force due to formation of plastic hinges at both ends of the beam plus the factored gravity load on the span. This is given by (see Fig. 4):

i) for sway to right:

$$V_{u,a} = V_a^{D+L} - 1.4 \left[\frac{M_{u,lim}^{As} + M_{u,lim}^{Bs}}{L_{AB}} \right]$$

$$\text{and } V_{u,b} = V_b^{D+L} + 1.4 \left[\frac{M_{u,lim}^{As} + M_{u,lim}^{Bs}}{L_{AB}} \right], \text{ and}$$

ii) for sway to left:

$$V_{u,a} = V_a^{D+L} + 1.4 \left[\frac{M_{u,lim}^{As} + M_{u,lim}^{Bs}}{L_{AB}} \right]$$

$$\text{and } V_{u,b} = V_b^{D+L} - 1.4 \left[\frac{M_{u,lim}^{As} + M_{u,lim}^{Bs}}{L_{AB}} \right],$$

where $M_{u,lim}^{As}$, $M_{u,lim}^{Bs}$ and $M_{u,lim}^{Bs}$, $M_{u,lim}^{As}$ are the sagging and hogging moments of resistance of the beam section at ends A and B, respectively. These are to be calculated as per IS 456 : 1978. L_{AB} is clear span of beam. V_a^{D+L} and V_b^{D+L} are the shears at ends A and B, respectively, due to vertical loads with a partial safety factor of 1.2 on loads. The design shear at end A shall be the larger of the two values of $V_{u,a}$ computed above. Similarly, the design shear at end B shall be the larger of the two values of $V_{u,b}$ computed above.

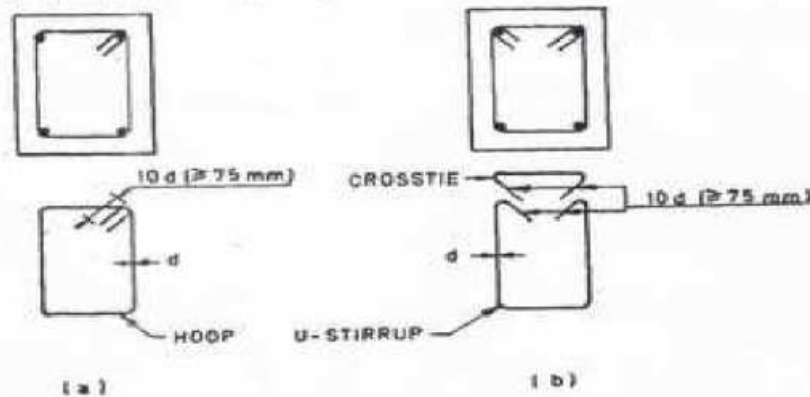

FIG. 3 BEAM WEB REINFORCEMENT

IS 13920 : 1993

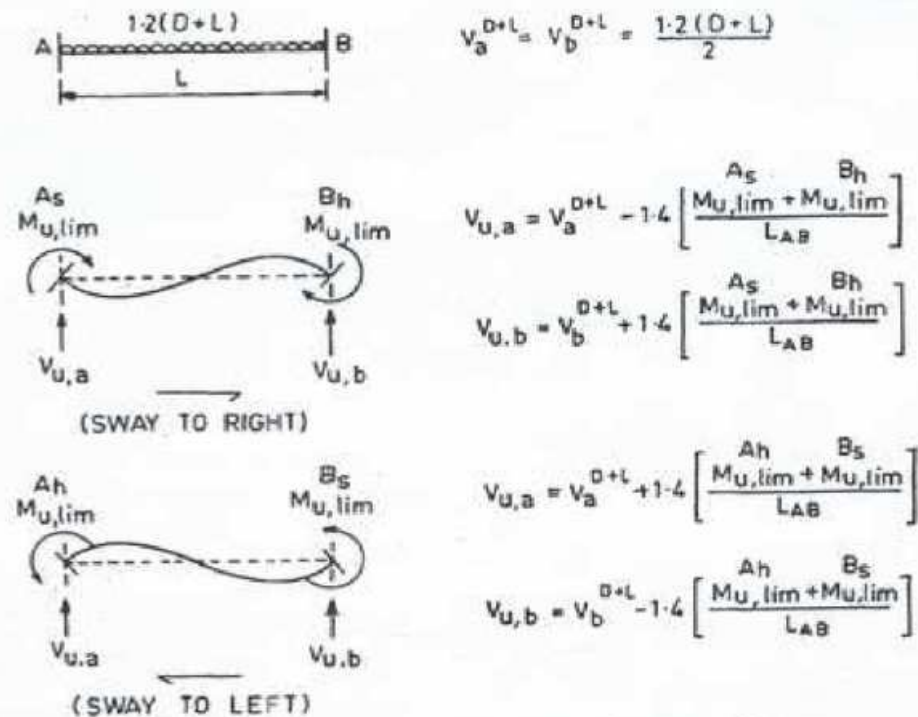

FIG. 4 CALCULATION OF DESIGN SHEAR FORCE FOR BEAM

6.3.4 The contribution of bent up bars and inclined hoops to shear resistance of the section shall not be considered.

6.3.5 The spacing of hoops over a length of $2d$ at either end of a beam shall not exceed (a) $d/4$, and (b) 8 times the diameter of the smallest longitudinal bar; however, it need not be less than 100 mm (see Fig. 5). The first hoop shall be at a distance not exceeding 50 mm from the joint face. Vertical hoops at the same spacing as above, shall also be provided over a length equal to $2d$ on either side of a section where flexural yielding may occur under the effect of earthquake forces. Elsewhere, the beam shall have vertical hoops at a spacing not exceeding $d/2$.

7.1.2 The minimum dimension of the member shall not be less than 200 mm. However, in frames which have beams with centre to centre span exceeding 5 m or columns of unsupported length exceeding 4 m, the shortest dimension of the column shall not be less than 300 mm.

7.1.3 The ratio of the shortest cross section dimension to the perpendicular dimension shall preferably not be less than 0.4.

7.2 Longitudinal Reinforcement

7.2.1 Lap splices shall be provided only in the central half of the member length. It should be proportioned as a tension splice. Hoops shall be provided over the entire splice length at spacing not exceeding 150 mm centre to centre. Not more than 50 percent of the bars shall be lapped at any section.

Detailing of beam as per I.A – 13920 Clause no . 7.1.7.2.7.3 , 7.4

6.3.4 The contribution of bent up bars and inclined hoops to shear resistance of the section shall not be considered.

6.3.5 The spacing of hoops over a length of $2d$ at either end of a beam shall not exceed (a) $d/4$, and (b) 8 times the diameter of the smallest longitudinal bar; however, it need not be less than 100 mm (see Fig. 5). The first hoop shall be at a distance not exceeding 50 mm from the joint face. Vertical hoops at the same spacing as above, shall also be provided over a length equal to $2d$ on either side of a section where flexural yielding may occur under the effect of earthquake forces. Elsewhere, the beam shall have vertical hoops at a spacing not exceeding $d/2$.

7 COLUMNS AND FRAME MEMBERS SUBJECTED TO BENDING AND AXIAL LOAD

7.1 General

7.1.1 These requirements apply to frame members which have a factored axial stress in excess of $0.1 f_{ck}$ under the effect of earthquake forces.

7.1.2 The minimum dimension of the member shall not be less than 200 mm. However, in frames which have beams with centre to centre span exceeding 5 m or columns of unsupported length exceeding 4 m, the shortest dimension of the column shall not be less than 300 mm.

7.1.3 The ratio of the shortest cross sectional dimension to the perpendicular dimension shall preferably not be less than 0.4.

7.2 Longitudinal Reinforcement

7.2.1 Lap splices shall be provided only in the central half of the member length. It should be proportioned as a tension splice. Hoops shall be provided over the entire splice length at spacing not exceeding 150 mm centre to centre. Not more than 50 percent of the bars shall be spliced at one section.

7.2.2 Any area of a column that extends more than 100 mm beyond the confined core due to architectural requirements, shall be detailed in the following manner. In case the contribution of this area to strength has been considered, then it will have the minimum longitudinal and transverse reinforcement as per this code.

IS 13920 : 1993

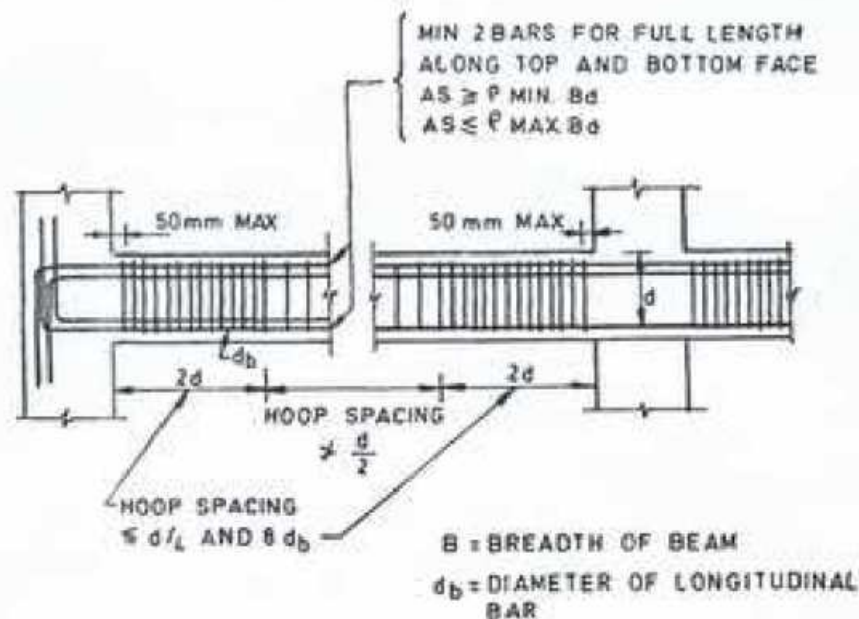

FIG. 5 BEAM REINFORCEMENT

However, if this area has been treated as non-structural, the minimum reinforcement requirements shall be governed by IS 456 : 1978 provisions minimum longitudinal and transverse reinforcement, as per IS 456 : 1978 (see Fig. 6).

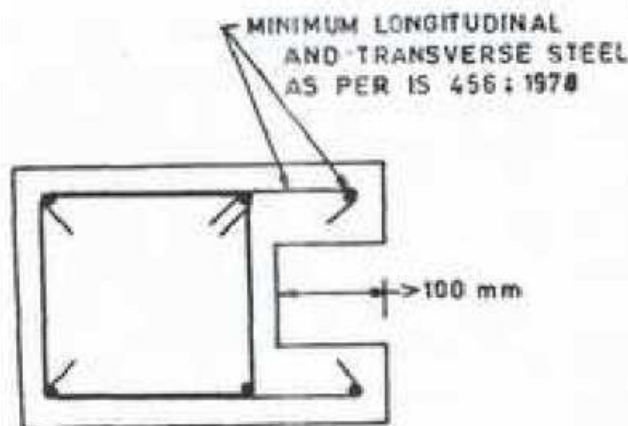

FIG. 6 REINFORCEMENT REQUIREMENT FOR COLUMN WITH MORE THAN 100 mm PROJECTION BEYOND CORE

7.3 Transverse Reinforcement

7.3.1 Transverse reinforcement for circular columns shall consist of spiral or circular hoops. In rectangular columns, rectangular hoops may be used. A rectangular hoop is a closed stirrup, having a 135° hook with a 10 diameter extension (but not $< 75 \text{ mm}$) at each end, that is embedded in the confined core (see Fig 7A).

7.3.2 The parallel legs of rectangular hoops shall be spaced not more than 300 mm centre to centre. If the length of any side of the hoop exceeds 300 mm, a cross tie shall be provided (Fig. 7B). Alternatively, a pair of overlapping hoops may be provided within the column (see Fig. 7C). The hooks shall engage peripheral longitudinal bars.

7.3.3 The spacing of hoops shall not exceed half the least lateral dimension of the column, except where special confining reinforcement is provided, as per 7.4.

7.3.4 The design shear force for columns shall be the maximum of:

- calculated factored shear force as per analysis, and
- a factored shear force given by

$$V_o = 1.4 \left[\frac{M_{u,lim}^{bL} + M_{u,lim}^{bR}}{h_{st}} \right]$$

where $M_{u,lim}^{bL}$ and $M_{u,lim}^{bR}$ are moment of resistance, of opposite sign, of beams framing into the column from opposite faces (see Fig. 8); and h_{st} is the storey height. The beam moment capacity is to be calculated as per IS 456 : 1978.

7.4 Special Confining Reinforcement

This requirement shall be met with, unless a larger amount of transverse reinforcement is required from shear strength considerations.

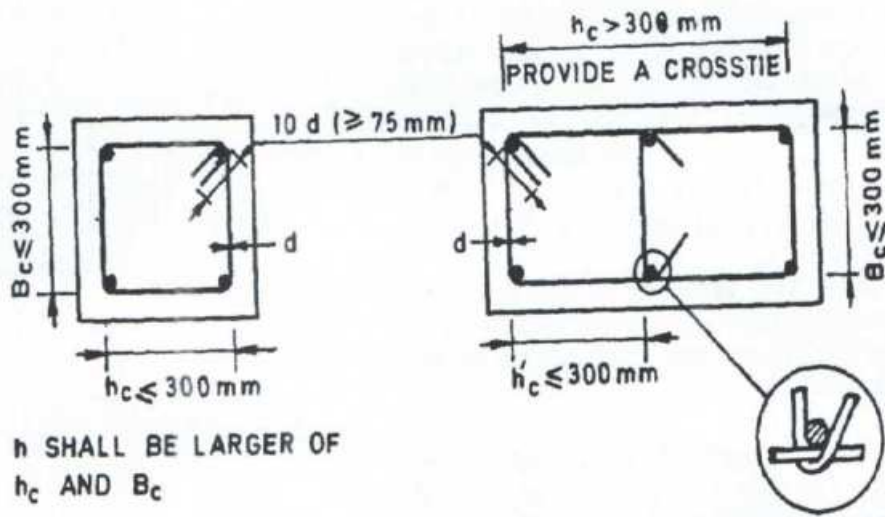

h SHALL BE LARGER OF h_c AND B_c

h SHALL BE LARGER OF h_c AND B_c

7A SINGLE HOOP

7B SINGLE HOOP WITH A CROSSTIE

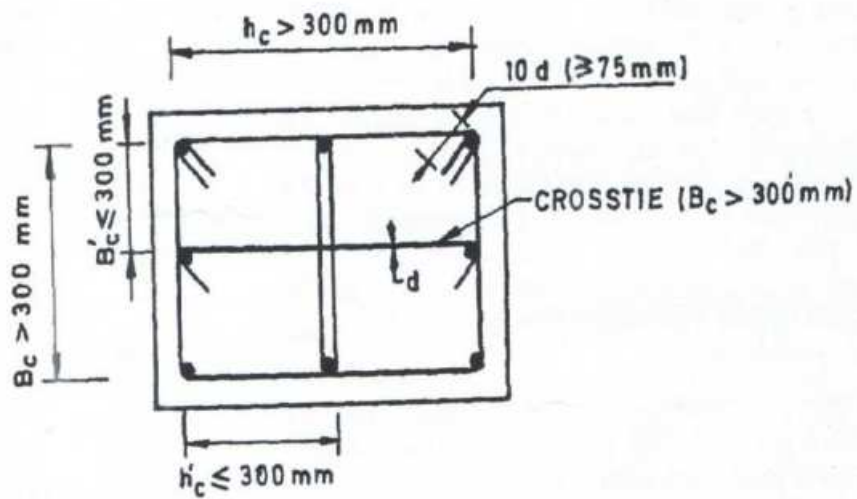

h SHALL BE LARGER OF h_c' AND B_c

7C OVERLAPPING HOOPS WITH A CROSSTIE

FIG. 7 TRANSVERSE REINFORCEMENT IN COLUMN

IS 13920 : 1993

7.4.1 Special confining reinforcement shall be provided over a length l_0 from each joint face, towards midspan, and on either side of any section, where flexural yielding may occur under the effect of earthquake forces (see Fig. 9.). The length ' l_0 ' shall not be less than (a) larger lateral dimension of the member at the section where yielding occurs, (b) 1/6 of clear span of the member, and (c) 450 mm.

7.4.2 When a column terminates into a footing or mat, special confining reinforcement shall extend at least 300 mm into the footing or mat (see Fig. 10).

7.4.3 When the calculated point of contraflexure, under the effect of gravity and earthquake loads, is not within the middle half of the member clear height, special confining reinforcement shall be provided over the full height of the column.

7.4.4 Columns supporting reactions from discontinued stiff members, such as walls, shall be provided with special confining reinforcement over their full height (see Fig. 11). This reinforcement shall also be placed above the discontinuity for at least the development length of the largest longitudinal bar in the column. Where the column is supported on a wall, this reinforcement shall be provided over the full height of the column; it shall also be provided below the discontinuity for the same development length.

7.4.5 Special confining reinforcement shall be provided over the full height of a column which has significant variation in stiffness along its height. This variation in stiffness may result

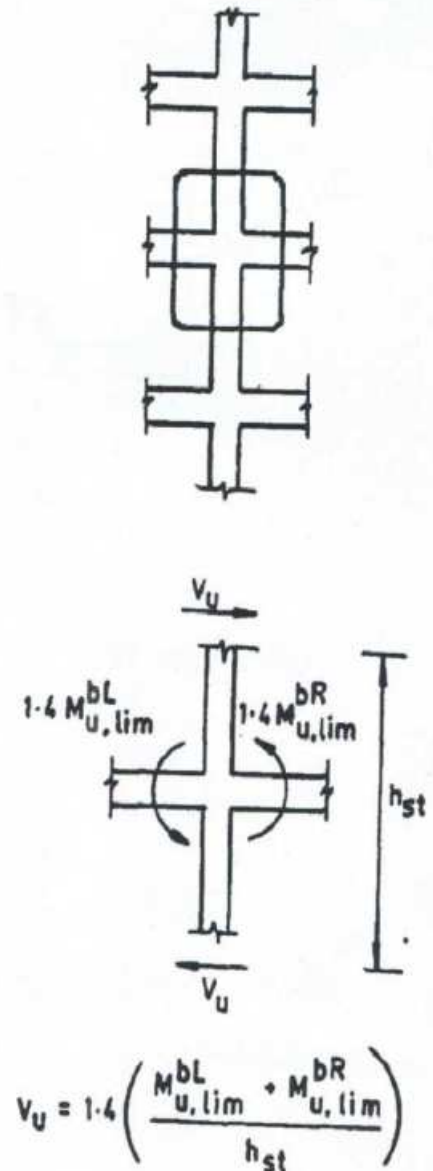

FIG. 8 CALCULATION OF DESIGN SHEAR FORCE FOR COLUMN

IS 13920 : 1993

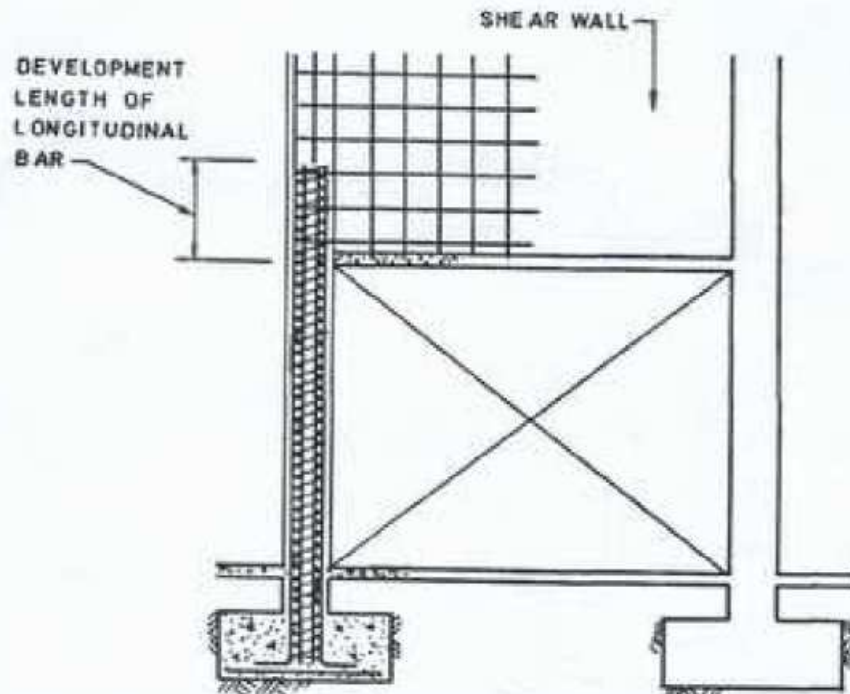

FIG. 11 SPECIAL CONFINING REINFORCEMENT REQUIREMENT FOR COLUMNS UNDER DISCONTINUED WALLS

due to the presence of bracing, a mezzanine floor or a R.C.C. wall on either side of the column that extends only over a part of the column height (see Fig. 12).

7.4.6 The spacing of hoops used as special confining reinforcement shall not exceed $1/4$ of minimum member dimension but need not be less than 75 mm nor more than 100 mm.

7.4.7 The area of cross section, A_{sh} , of the bar forming circular hoops or spiral, to be used as special confining reinforcement, shall not be less than

$$A_{sh} = 0.09 S D_k \frac{f_{ck}}{f_y} \left[\frac{A_g}{A_k} - 1.0 \right]$$

where

- A_{sh} = area of the bar cross section,
- S = pitch of spiral or spacing of hoops,
- D_k = diameter of core measured to the outside of the spiral or hoop,
- f_{ck} = characteristic compressive strength of concrete cube,
- f_y = yield stress of steel (of circular hoop or spiral),
- A_g = gross area of the column cross section, and

$$A_k = \text{area of the concrete core} = \frac{\pi}{4} D_k^2$$

Example : Consider a column of diameter 300 mm. Let the grade of concrete be M20, and that of steel Fe 415, for longitudinal and confining reinforcement. The spacing of circular hoops, S , shall not exceed the smaller of (a) $1/4$ of minimum member dimension = $1/4 \times 300 = 75$ mm, and (b) 100 mm. Therefore, $S = 75$ mm. Assuming 40 mm clear cover to the longitudinal reinforcement and circular hoops of diameter 8 mm, $D_k = 300 - 2 \times 40 + 2 \times 8 = 236$ mm. Thus, the area of cross section of the bar forming circular hoop works out to be 47.28 mm^2 . This is less than the cross sectional area of 8 mm bar (50.27 mm^2). Thus, circular hoops of diameter 8 mm at a spacing of 75 mm centre to centre will be adequate.

7.4.8 The area of cross section, A_{sh} , of the bar forming rectangular hoop, to be used as special confining reinforcement shall not be less than

$$A_{sh} = 0.18 S h \frac{f_{ck}}{f_y} \left[\frac{A_g}{A_k} - 1.0 \right]$$

where

- h = longer dimension of the rectangular confining hoop measured to its outer

IS 13920 : 1993

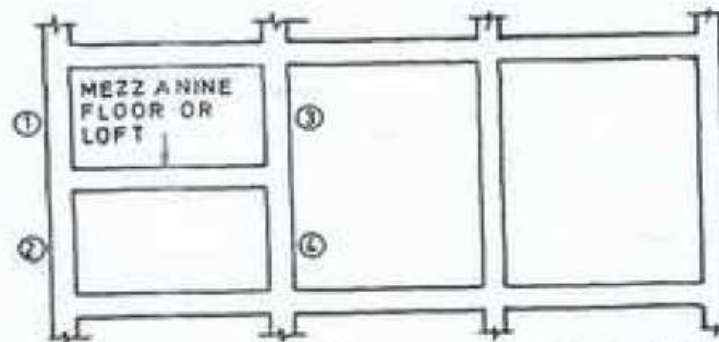
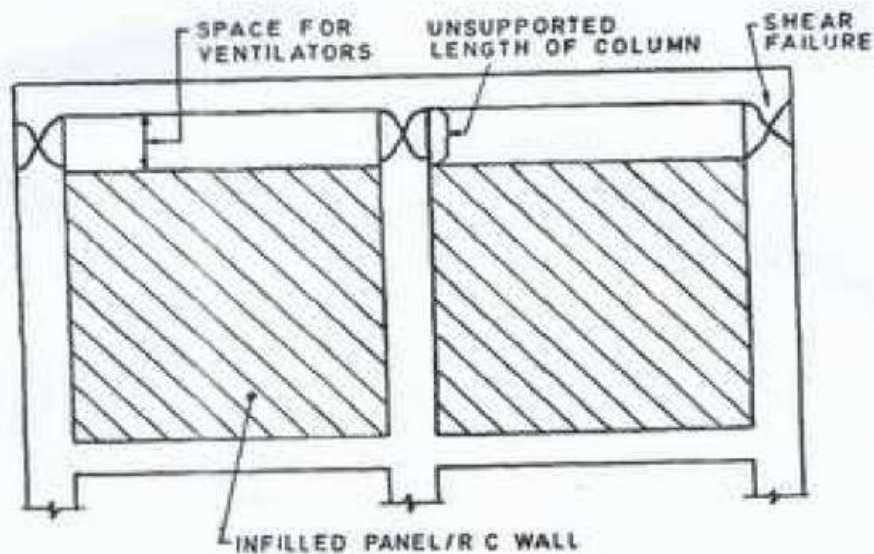

(1), 2), (3) and (4) relatively stiff columns — They attract large seismic shear force.

FIG. 12 COLUMNS WITH VARYING STIFFNESS

face. It shall not exceed 300 mm (see Fig. 7), and

A_k = area of confined concrete core in the rectangular hoop measured to its outside dimensions.

NOTE: The dimension 'h' of the hoop could be reduced by introducing cross-ties, as shown in Fig. 7B. In this case, A_k shall be measured as the overall core area, regardless of the hoop arrangement. The hooks of cross-ties shall engage peripheral longitudinal bars.

Example: Consider a column of 650 mm × 500 mm. Let the grade of concrete be M20 and that of steel Fe 415, for the longitudinal and confining reinforcement. Assuming clear cover of 40 mm to the longitudinal reinforcement and rectangular hoops of diameter 10 mm, the size of the core is 590 mm × 440 mm. As both these dimensions are greater than 300 mm,

either a pair of overlapping hoops or a single hoop with cross-ties, in both directions, will have to be provided. Thus, the dimension 'h' will be the larger of (i) $590/2 = 295$ mm, and (ii) $440/2 = 220$ mm. The spacing of hoops, S , shall not exceed the smaller of (a) $1/4$ of minimum member dimensions = $1/4 \times 500 = 125$ mm, and (b) 100 mm. Thus, $S = 100$ mm. The area of cross section of the bar forming rectangular hoop works out to be 64.47 mm^2 . This is less than the area of cross section of 10 mm bar (78.54 mm^2). Thus, 10 mm diameter rectangular hoops at 100 mm c/c will be adequate. Similar calculations indicate that, as an alternative, one could also provide 8 mm diameter rectangular hoops at 70 mm c/c.

8 JOINTS OF FRAMES

8.1 The special confining reinforcement as required at the end of column shall be provided

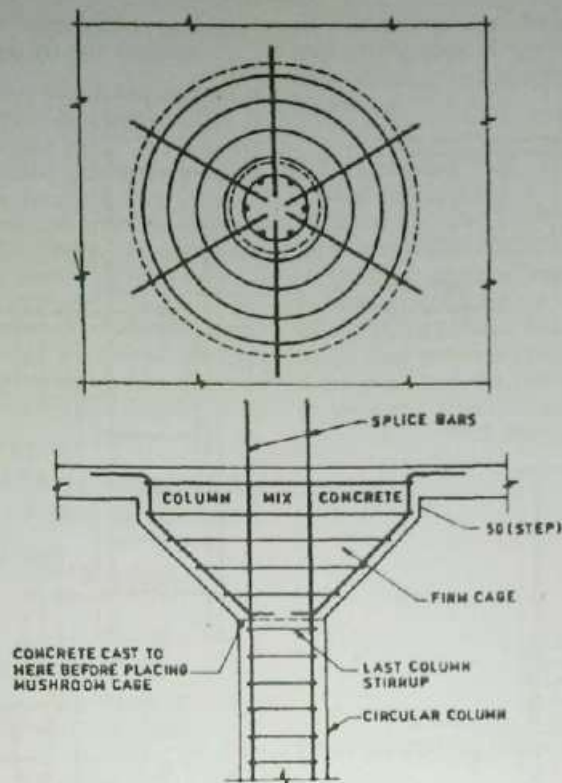

FIG. 7.12 REINFORCEMENT OF MUSHROOM HEADS

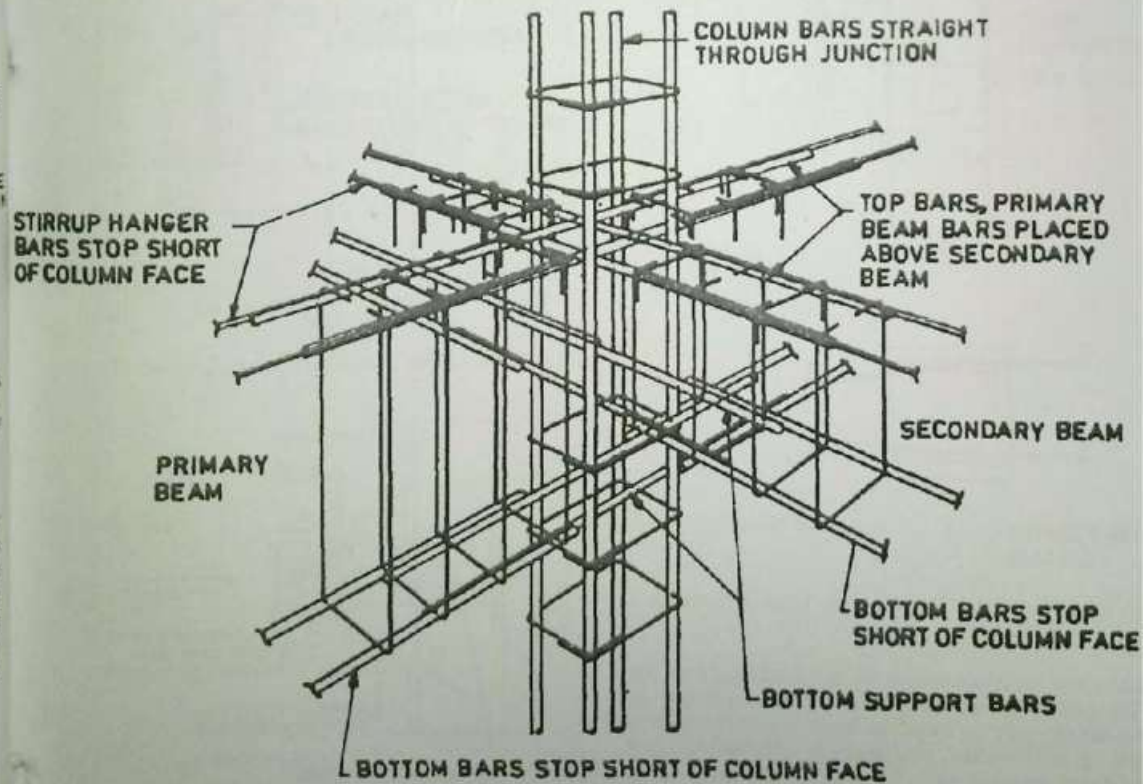

FIG. 7.13 BEAM-COLUMN INTERSECTION

